

FRONT VIEW

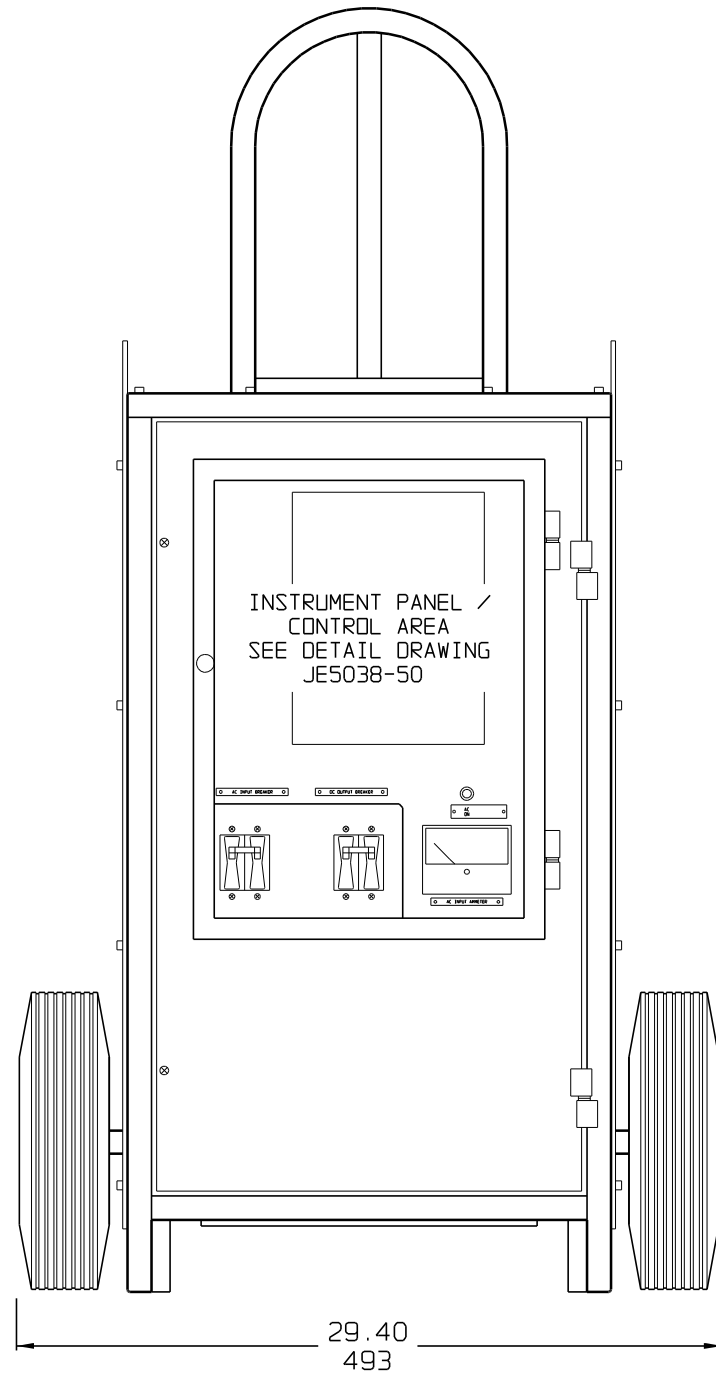

SIDE VIEW

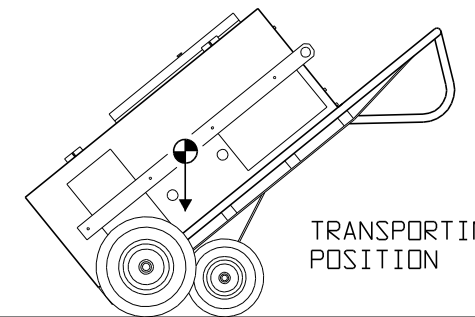
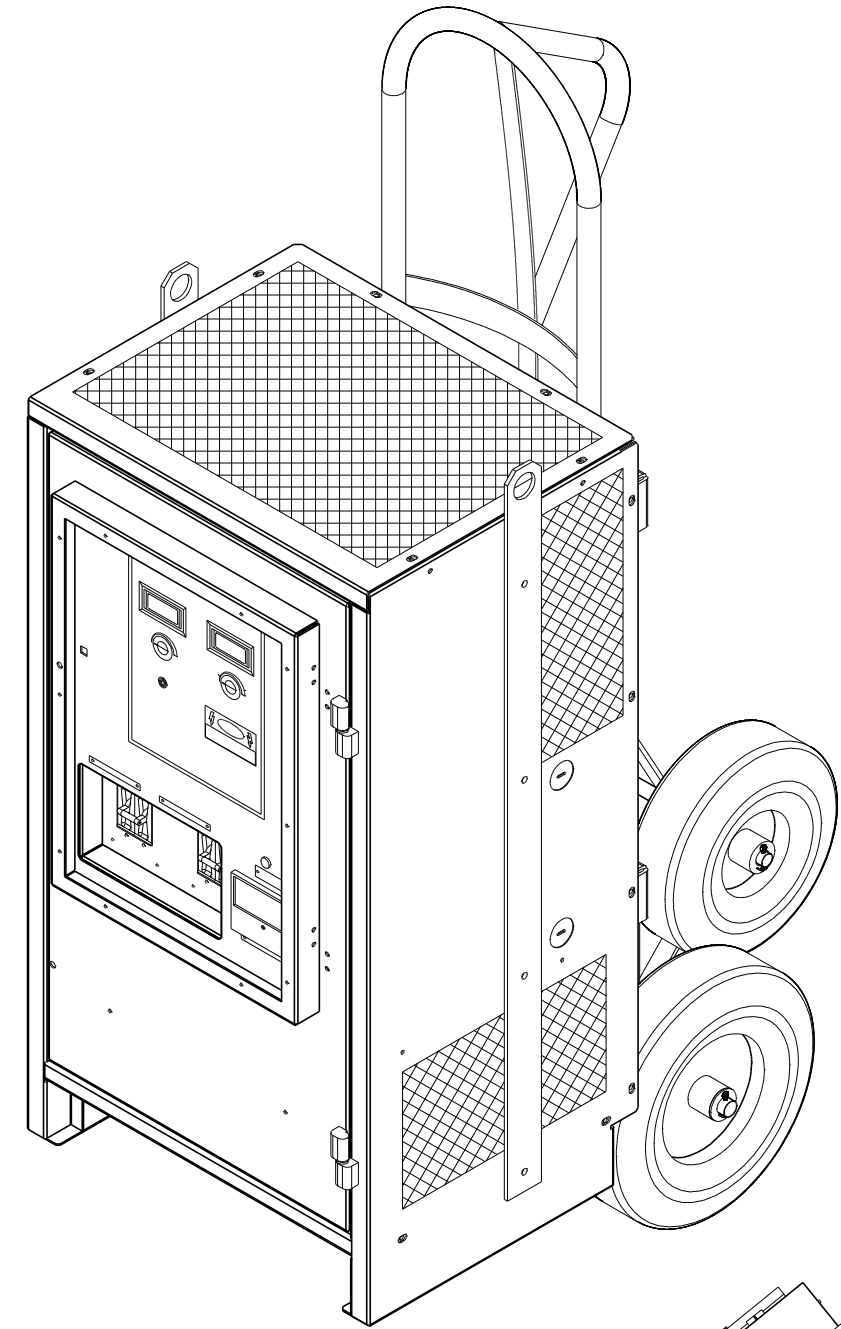
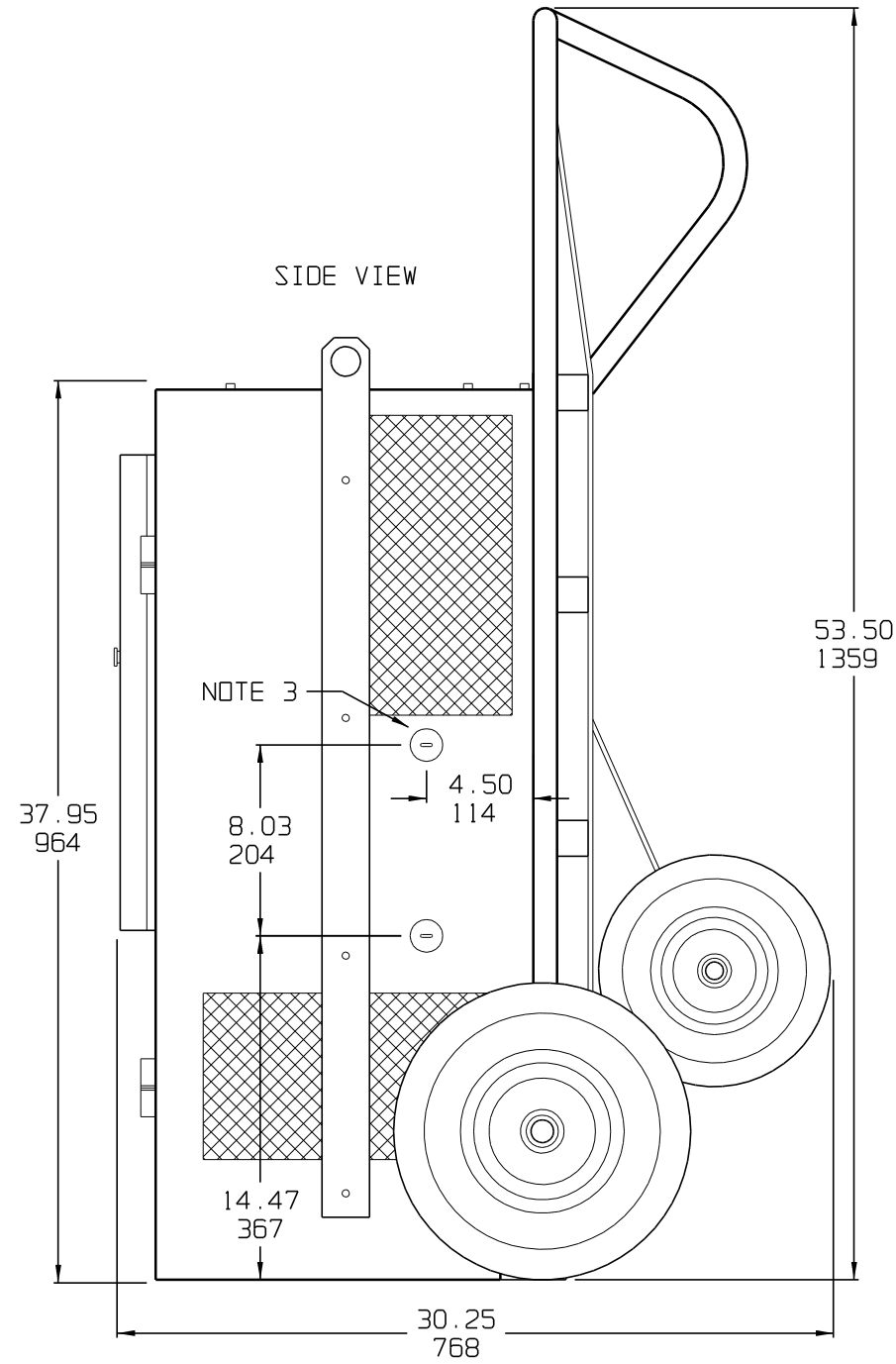

NOTES:

- 1) ENCLOSURE IS A NEMA-1 / IP20 TYPE STEEL CABINET WITHOUT GASKETS, FINISH IS ANSI-61 GRAY EPOXY POWDERCOAT.
- 2) ALLOW 12in / 305mm OF FREE AIR ALL AROUND CABINET FOR VENTILATION.
- 3) TWO (2) 1in/25mm I/O CONDUIT KNOCKOUTS ARE PROVIDED AS SHOWN ON THE LOWER-RIGHT SIDE OF ENCLOSURE.
- 4) BATTERY CHARGER SHIPPING WEIGHT: APPROXIMATELY 390 lbs. / 177 kg.

DUAL DIMENSIONS in mm

6	21450	120808	THIRD ANGLE PROJECTION	1075 Saint John Street Easton, PA 18042-6661 PH 610-330-9000 FAX 610-330-8510 www.hindlepowerinc.com
5	20462	121506		
4	20385	102006	DRAWN BY MCR 021403	TITLE UNIVERSAL MAINTENANCE CHARGER OUTLINE: NEMA-1 STYLE-5018 ENCL W/HAND TRUCK
3	20277	072006	ELECTRONIC APPROVAL SIGNATURES MAINTAINED BY MFG ECN LOG	DRAWING No JE5036-50 REV 6 B
2	20100	051606	UNLESS OTHERWISE NOTED DIMENSIONS ARE IN INCHES. TOLERANCES ARE:	SCALE NTS PART No JE5036-50 SHEET 1 OF 1
REV	ECN No	DATE		