

## RECOMMENDED PROCEDURE

- 1) TURN BOTH AC AND DC CIRCUIT BREAKERS TO OFF POSITIONS.
- 2) REMOVE PLEXIGLASS COVER AND APPLICABLE "GND" HARDWARE
- 3) IF GROUND LUG IS ORDERED, OMIT STEP 5.
- 4) INSTALL 1/4-20x1" BOLT (ITEM #5) THROUGH APPROPRIATE MOUNTING HOLE, AS SHOWN BELOW. FASTEN ANY APPLICABLE CONNECTIONS OVER BOLT TO TOP OF BUSS. TORQUE NUT (ITEM #5) AND SPLIT WASHER (ITEM #7) ACCORDING TO TABLE.
- 5) IF GROUND LUG OPTION IS ORDERED MOUNT GROUND LUG (ITEM #8), SPLIT WASHER (ITEM #9), AND HEX NUT (ITEM #10) AS SHOWN BELOW. TORQUE HARDWARE ACCORDING TO TABLE.
- 6) POSITION GROUND BUSS (ITEM #1 WITH ASSEMBLED HARDWARE FROM STEP 2) OVER TERMINAL STUDS AS SHOWN BELOW. POSITION ALL GROUND WIRE CONNECTIONS AND WIRE ASSEMBLY (ITEM #12) OVER THE "GND" TERMINAL STUD AND ON TOP OF BUSS. TORQUE NUTS ACCORDING TO TABLE BELOW.

- 7) MOUNT OTHER END OF GROUND WIRE ASSEMBLY (ITEM #12) TO VENTED BASE WITH 10-32x1" BOLT (ITEM #13), EXTERNAL WASHERS (ITEM #14) AND HEX NUT (ITEM #15) AS SHOWN IN DETAIL 1. LUGS SHOULD BE POSITIONED APPROXIMATELY THREE TO FIVE INCHES BEHIND THE DC CIRCUIT BREAKER. SEE TABLE BELOW FOR TORQUE VALUES.
- 8) CHECK ALL HARDWARE USED IN STEPS ABOVE FOR LOOSE CONNECTIONS.
- 8) REPLACE PLEXIGLASS COVER ACCORDING TO DETAIL 2. FASTEN WING NUT SNUG TO COVER.

### BILL OF MATERIAL: EI0195-00

ITEM NUMBER	PART No.	DESCRIPTION	QUANTITY PER ASSY
①	FF0200-00	GROUND BUSS, AT10	1
②	PE0088-06	WASHER, BRASS, FLAT, #10	1
③	PE0007-06	WASHER, ZPS, SPLIT LOCK, #10	1
④	PE0014-06	NUT, ZPS, HEX, 10-32	1
⑤	PE0025-04	SCREW, ZPS, HHTB, 1/4-20x1"	1
⑥	PE0007-08	WASHER, ZPS, SPLIT-LOCK, 1/4	1
⑦	PE0014-07	NUT, ZPS, HEX, 1/4-20	1
⑧	EJ1134-00	WIRE ASSEMBLY, GROUND BUSS, AT10	1
⑨	PE0035-10	SCREW, ZPS, SLOTTED, RHMS, 10-32x1"	1
⑩	PE0008-06	WASHER, ZPS, EXT, LOCK, #10	2
⑪	PE0269-06	NUT, SERRATED-FLANGE, LOCK, 10-32	1

### BILL OF MATERIAL: EI0195-01

ITEM NUMBER	PART No.	DESCRIPTION	QUANTITY PER ASSY
-	EI0195-00	ASSEMBLY, GROUND BUSS, AT10	1
⑫	PE0035-10	SCREW ZPS, SLOTTED, RHMS, 10-32x1"	1
⑬	RC0056-04	LUG, TERMINAL, UTILITY, 14-6 AWG.	1
⑭	PE0007-06	WASHER, ZPS, SPLIT LOCK, #10	1
⑮	PE0014-06	NUT, ZPS, HEX, 10-32	1

NOTE: ITEMS #5, #6 AND #7 ARE NOT INCLUDED WITH BILL OF MATERIAL EI0195-01.

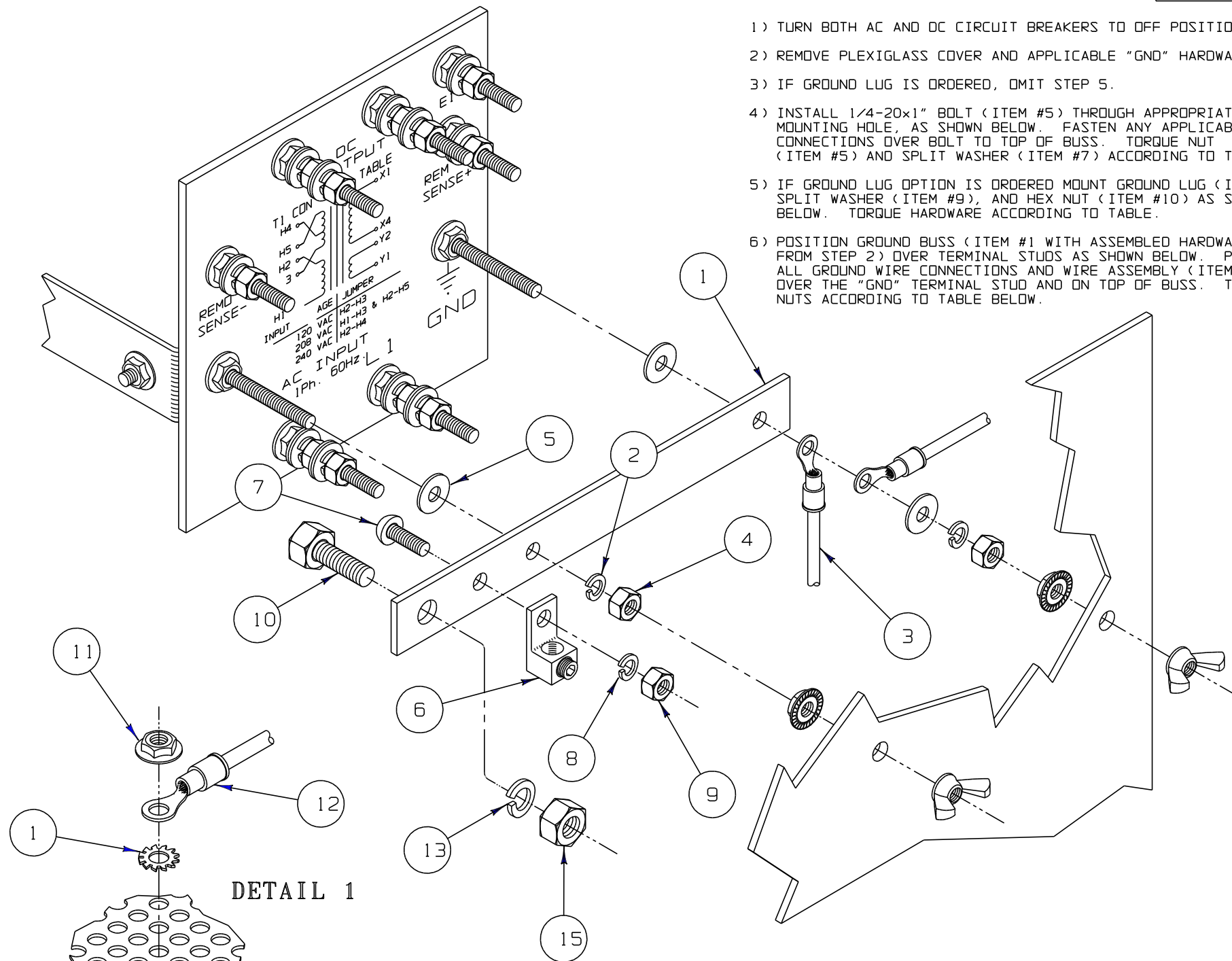

**DETAIL 1**

TYPICAL SECTION OF VENTED BOTTOM PANEL - LOCATE GROUND BOLT IN AREA DIRECTLY BEHIND DC CIRCUIT BREAKER CB2

TORQUE SPECIFICATIONS	
BOLT SIZE	TORQUE RANGE
8	10-15
10	16-24
1/4	57-77
5/16	119-158
3/8	17-23 (*)
1/2	43-57 (*)

ALL TORQUE RANGES ARE IN IN-LBS EXCEPT AS NOTED (\*) RATED IN FT-LBS

### REVISIONS

REV	ECN No	DATE	APP	APPROVALS	DATE
0		082090		DRAWN BY PAC	082090
				APPROVED	

UNLESS OTHERWISE NOTED DIMENSIONS ARE IN INCHES. TOLERANCES ARE:

FRA. DEC. ANG.  
± 1/64 ± 0.015 ± 0.05

### DETAIL 2

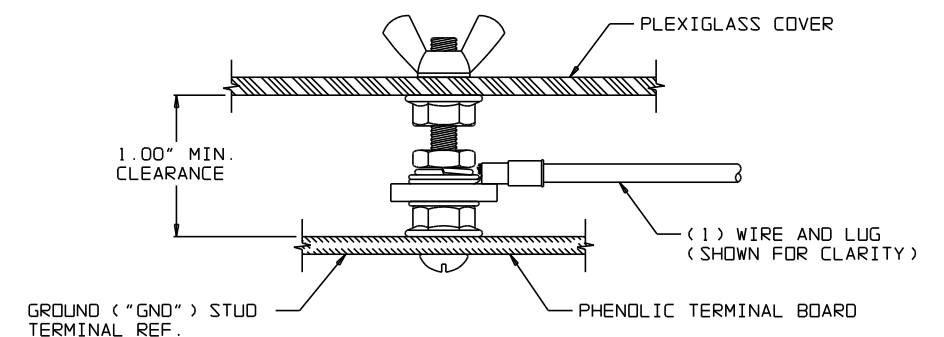

TITLE		AT10 SERIES GROUND BUSS CUSTOMER INSTRUCTIONS	
DRAWING No		JA0096	
REV	0	SHEET	01 OF 01
SCALE	-	JOB No	-

B