

LEFT SIDE VIEW

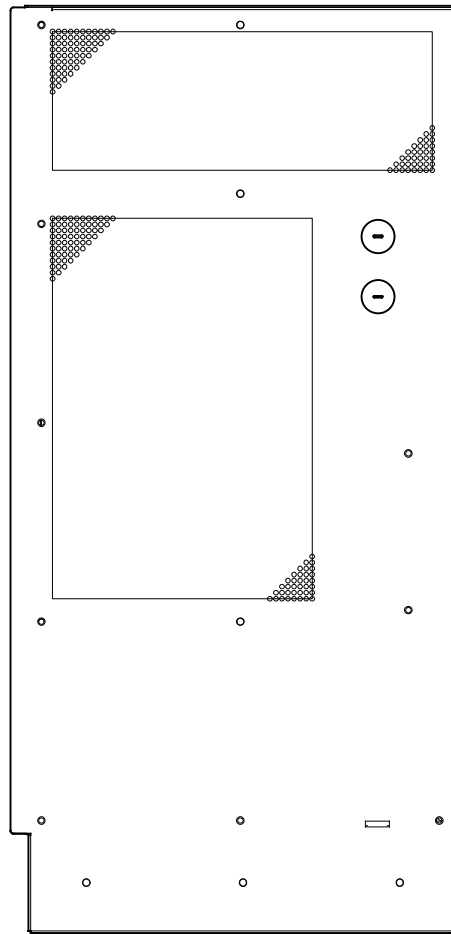

FRONT VIEW

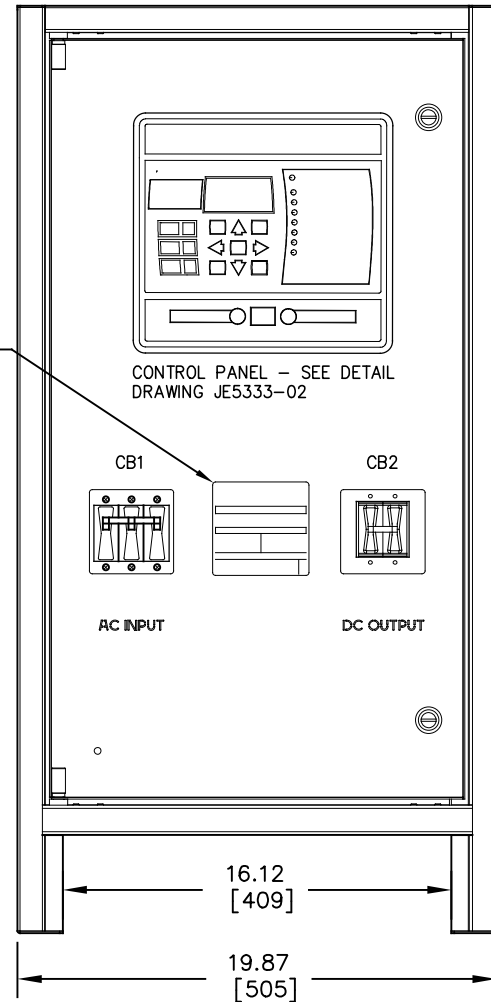

RIGHT SIDE VIEW

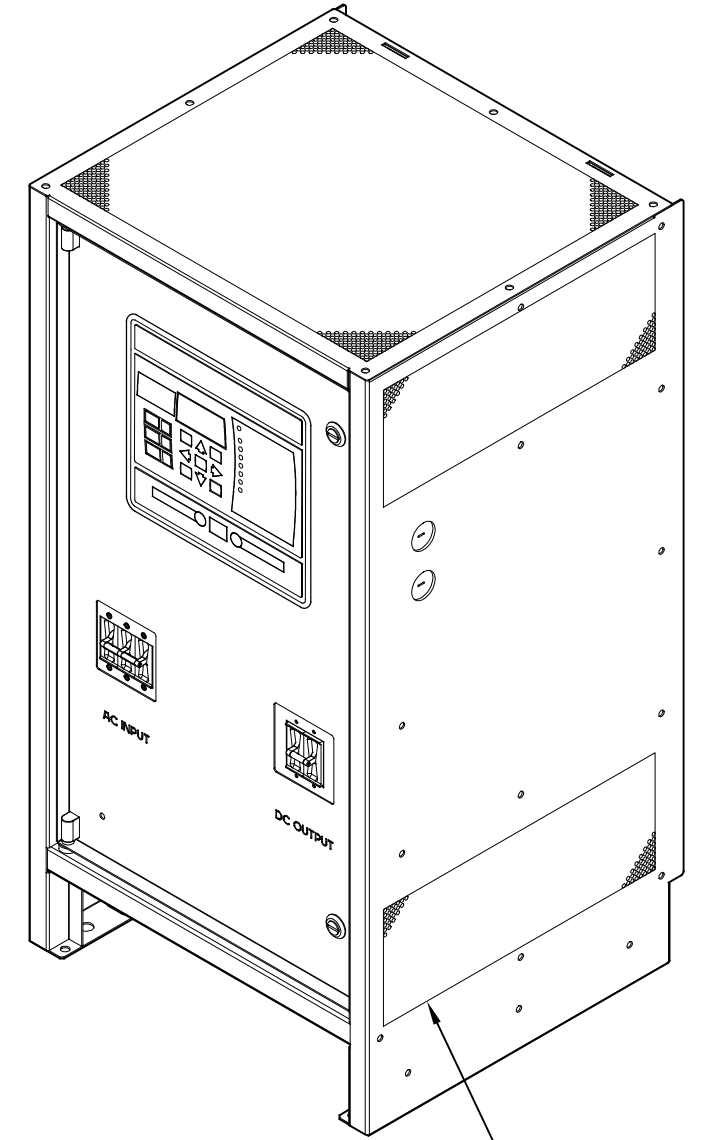
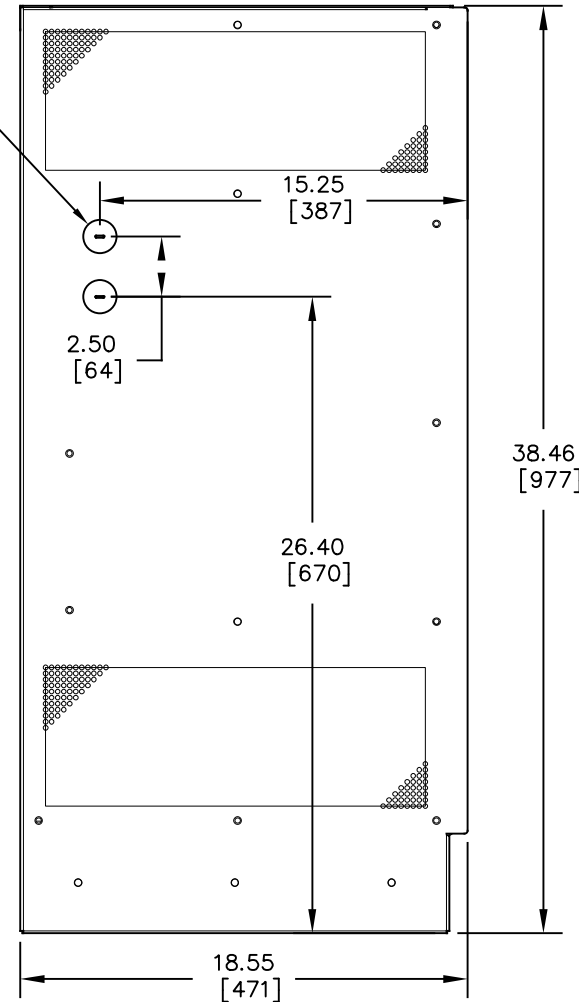

NOTES:

- ENCLOSURE IS A NEMA TYPE 1 / IP20 TOP-VENTED STEEL CABINET WITHOUT GASKETS. FINISH IS ANSI-61 GRAY EPOXY POWDERCOAT. MOUNTING BASE IS 12 GA. SIDE PANELS ARE 14 GA. TOP PANEL AND DOOR ARE 16 GA.
- ALLOW 6in / 152mm OF FREE AIR ON ALL VENTED SURFACES (TOP, SIDES & REAR) FOR COOLING.
- DATA NAMEPLATE (WITH CHARGER RATINGS) MOUNTED ON DOOR.
- FOUR (4) 0.5in / 12mm FLOOR-MOUNTING HOLES AND FOUR (4) 1in x 0.625in / 25mm x 16mm FLOOR-MOUNTING SLOTS ARE PROVIDED ON BOTTOM OF ENCLOSURE AS SHOWN.
- FOUR (4) 1.31in / 33mm DIA STANDARD PRE-FAB KEY-SLOT KNOCKOUTS ARE PROVIDED AS SHOWN FOR 1in / 25mm CONDUIT ENTRY. IF ADDITIONAL CONDUIT ENTRANCES ARE REQUIRED, ENCLOSURE SHOULD BE FIELD-MODIFIED BY INSTALLER.
- BATTERY CHARGER SHIPPING WEIGHT: APPROXIMATELY TBD lbs / TBD kg

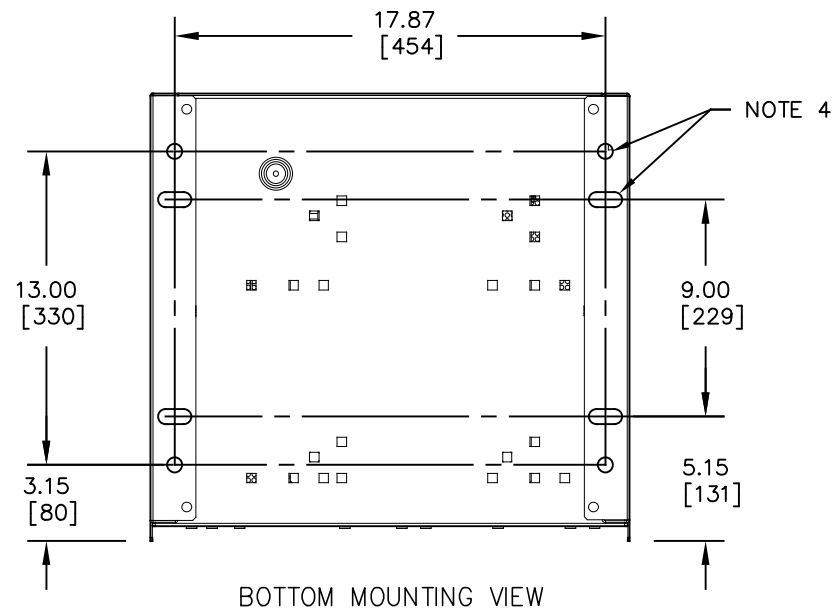

DUAL DIMENSIONS in [mm]

REV. 1	DRN BY KJB	CHK BY MCR	APP BY MCR	DATE 2/24/22	DRN BY KJB	DATE 11/05/19
DESCRIPTION STANDARD DRAWINGS.					CHK BY MCR	DATE 11/05/19
ECN No. N/A					APP BY MCR	DATE 11/05/19

HINDLEPOWER

1075 Saint John Street
Easton, PA 18042-6661
PH 610-330-9000 FAX 610-330-8510
www.hindlepowerinc.com

TITLE
**ATEVO BATTERY CHARGER
OUTLINE: NEMA-1 STYLE-5070 ENCL
3Ø W/O OPTIONS 75-100A**

B SCALE DWG No
NTS JE5331-02

REV 1 SHEET 1 OF 1

SYM STANDARD COMPONENT DESCRIPTION	
A1	MAIN CONTROL PC BOARD
A2	POWER BOARD
A16	RECTIFIER H/S ASSEMBLY
C1	FILTER CAPACITOR
A9	MOV PC BOARD
CB1	AC INPUT CIRCUIT BREAKER (CD3)
CB2	DC OUTPUT CIRCUIT BREAKER (CD2)
AUXCB2	DC CKT BKR (CB2) AUXILIARY CONTACTS
L1	MAIN INDUCTOR
L2	FILTER INDUCTOR
T1	POWER TRANSFORMER

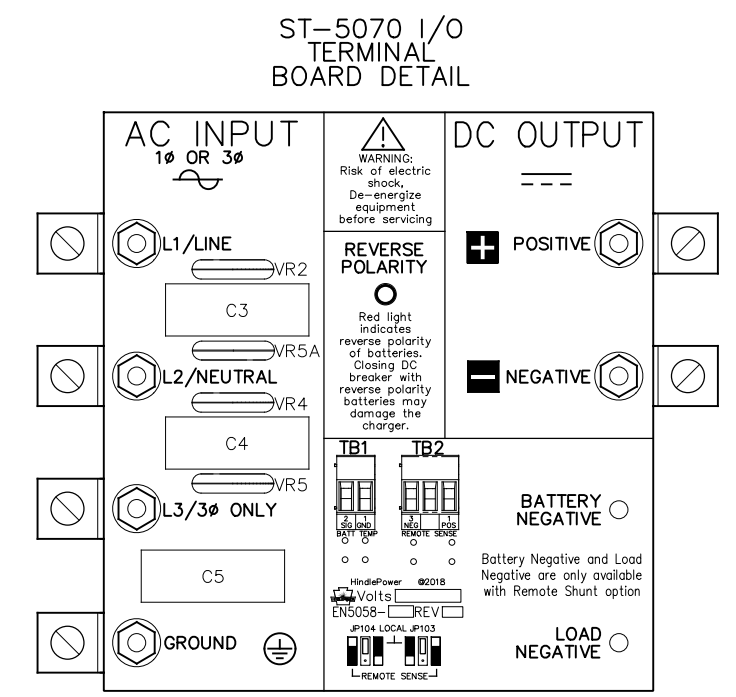
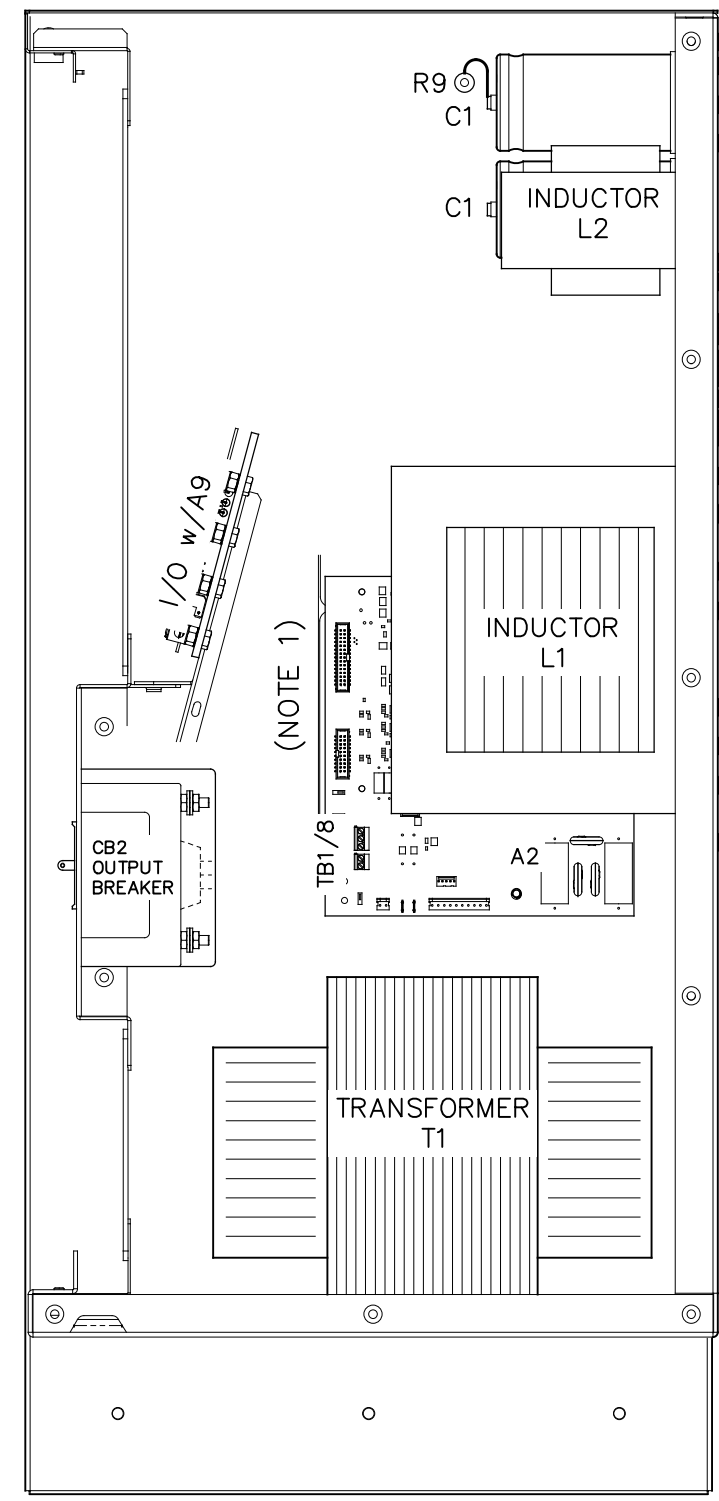
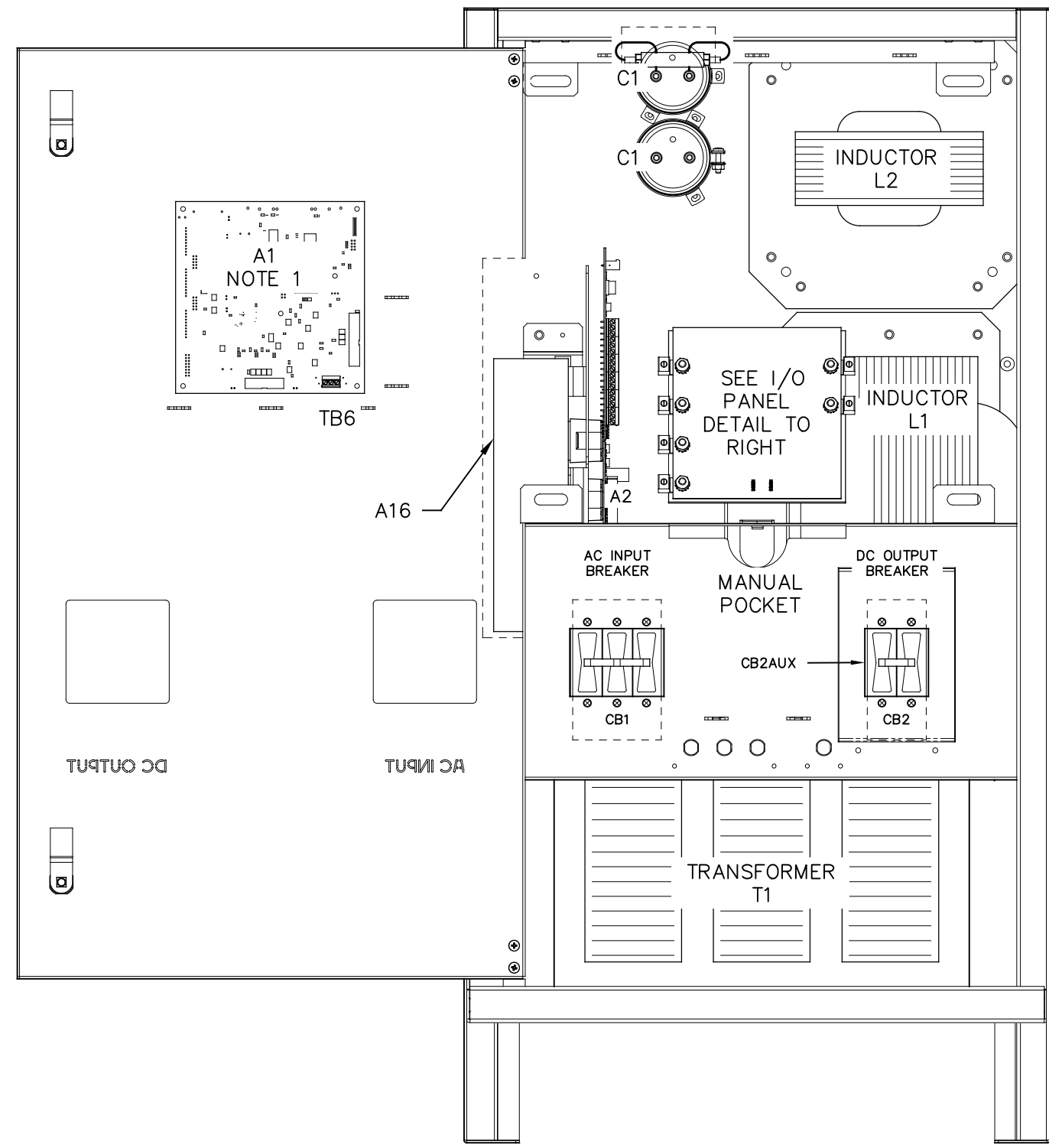

MOV PC BOARD (A9)

I/O TERMINAL	DESCRIPTION - TYPE	CONNECTION
I/O (+/-)	POS/NEG OUTPUT TERMINALS - CU-ALUMINUM COMPRESSION LUG	#14-1/0 AWG
GND LUG	USER GROUND TERMINAL - CU-ALUMINUM COMPRESSION LUG	#14-1/0 AWG
I/O (L1/L2)	AC INPUT TERMINALS - CU-ALUMINUM COMPRESSION LUG	#14-1/0 AWG
(A1) TB6	SUMMARY ALARM TERMINAL BLOCK (A1) - SOLDERLESS COMPRESSION SCREW	#22-14 AWG
(A2) TB1	POS/NEG REMOTE SENSE TERMS (A2) - SOLDERLESS COMPRESSION SCREW	#22-14 AWG
(A2) TB8	TEMPCO PROBE (A10) TERM BLK - SOLDERLESS COMPRESSION SCREW	#22-14 AWG

NOTES:
1. FOR DETAIL VIEWS OF ALL PC BOARDS (A1, A2, etc.) SEE DRAWING JE5333-02.

REV. 1	DRN BY KJB	CHK BY MCR	APP BY MCR	DATE 11/05/19	DRN BY KJB	DATE 11/05/19
DESCRIPTION				STANDARD DRAWINGS.	CHK BY MCR	DATE 11/05/19
ECN No. N/A				APP BY MCR	DATE 11/05/19	

HINDLEPOWER

1075 Saint John Street
Easton, PA 18042-6661
PH 610-330-9000 FAX 610-330-8510
www.hindlepowerinc.com

TITLE
ATEVO BATTERY CHARGER
INTERNAL COMPONENT LAYOUT: STYLE-5070
3Ø W/O OPTIONS 75-100A

B SCALE DWG No
NTS JE5332-02

REV 1 SHEET 1 OF 1

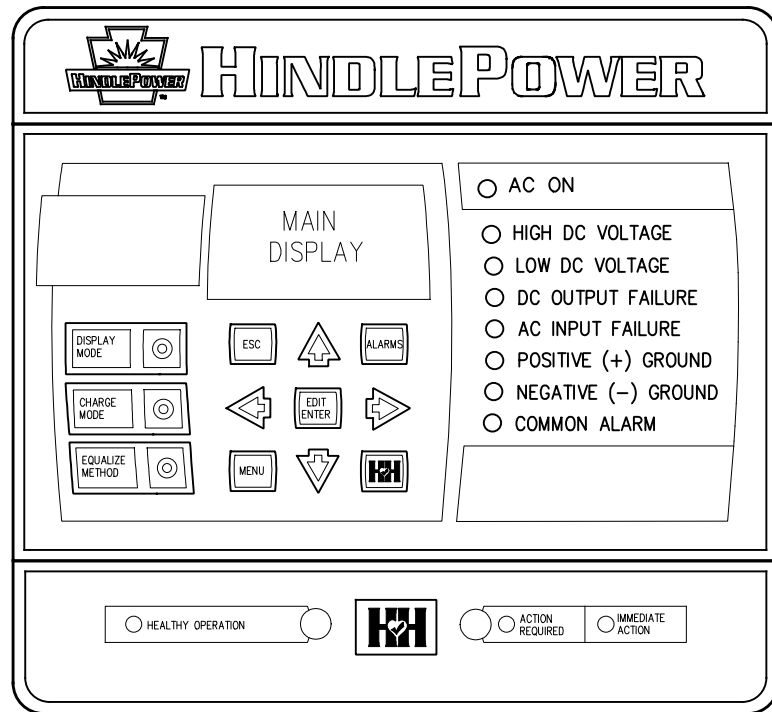

CONTROL PANEL
(PART No. FK5047-00)

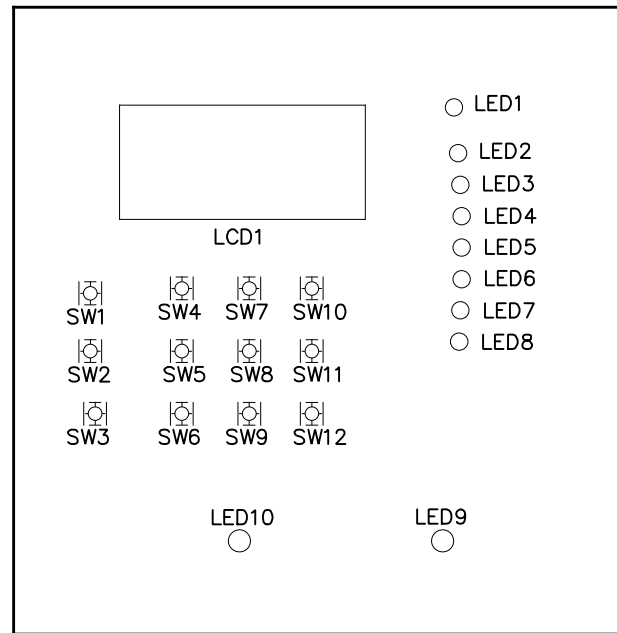

MAIN CONTROL PC BOARD (A1)
FRONT VIEW - FACING CHARGER DOOR WHEN INSTALLED

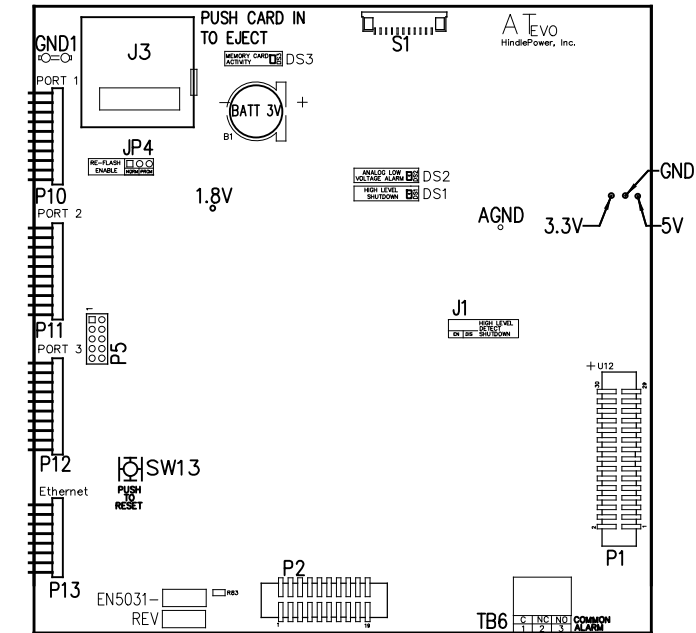

MAIN CONTROL PC BOARD (A1)
BACK VIEW - FACING CHARGER COMPONENTS WHEN INSTALLED

NOTE: ALL ALARM CONTACTS ARE ENERGIZED WHEN IN THE NON-ALARM STATE (FAIL SAFE). ALL ALARM CONTACTS WILL CHANGE STATE WHEN CHARGER IS POWERED DOWN. CONTACT RATING IS 0.5A @ 125VAC/VDC RESISTIVE.

MAIN CONTROL PC BOARD (A1)

INDICATOR LIGHTS (LEDs):

- LED1 - GREEN - AC ON
- LED2 - RED - HIGH DC VOLTAGE ALARM
- LED3 - RED - LOW DC VOLTAGE ALARM
- LED4 - RED - DC OUTPUT FAILURE ALARM
- LED5 - RED - AC INPUT FAILURE ALARM
- LED6 - RED - POSITIVE (+) GROUND ALARM
- LED7 - RED - NEGATIVE (-) GROUND ALARM
- LED8 - RED - COMMON ALARM
- LED9 - RED - ACTION REQUIRED ALARM
- LED10 - GREEN - HEALTHY OPERATION
- DS1 - RED - HIGH LEVEL SHUTDOWN (HLD)
- DS2 - RED - ANALOG LOW VOLTAGE ALARM (LLD)
- DS3 - RED - MEMORY CARD ACTIVITY

JUMPERS:

- J1 - ANALOG HIGH VOLTAGE SHUTDOWN JUMPER
- J3 - SD CARD PORT
- JP4 - RE-FLASH (FIELD PROGRAMMING) JUMPER
- TERMINAL BLOCKS:
- TB6 - COMMON ALARM RELAY CONTACTS
- TEST POINTS:
- 1.8V - 1.8 VOLTS
- 3.3V - 3.3 VOLTS
- 5V - 5.0 VOLTS
- GND - GROUND
- AGND - ANALOG GROUND
- SDA - MAIN BOARD I2C DATA
- SCL - MAIN BOARD I2C CLOCK

SWITCHES:

- S1 - DISPLAY BUTTON
- S2 - CHARGE MODE BUTTON
- S3 - EQUALIZE METHOD BUTTON
- S4 - ESCAPE (ESC) BUTTON
- S5 - LEFT ARROW BUTTON
- S6 - MENU BUTTON
- S7 - UP ARROW BUTTON
- S8 - EDIT / ENTER BUTTON
- S9 - DOWN ARROW BUTTON
- S10 - ALARM BUTTON
- S11 - RIGHT ARROW BUTTON
- S12 - HINDLE HEALTH (HHS) BUTTON
- SW13 - SYSTEM RESET BUTTON (BACK OF BOARD)

CONNECTORS:

- P1 - POWER BOARD RIBBON
- P2 - 3 PHASE RECTIFIER RIBBON
- P3 - USB EXPANSION PORT
- P4 - SPI & I2C EXPANSION PORT #1
- P5 - SPI & I2C EXPANSION PORT #2
- P6 - DISPLAY SPI PORT
- P7 - DISPLAY JTAG PORTS
- P10 - SERIAL INTERFACE PORT #1
- P11 - SERIAL INTERFACE PORT #2
- P12 - SERIAL INTERFACE PORT #3
- P13 - ETHERNET INTERFACE PORT
- P17 - GENERAL EXPANSION PORT

I/O TERMINAL	DESCRIPTION - TYPE	CONNECTION
(A1) TB6	SUMMARY ALARM TERMINAL BLOCK (A1) - SOLDERLESS COMP SCREW	#22-14 AWG

REV. 1	DRN BY KJB	CHK BY MCR	APP BY MCR	DATE 11/05/19	DRN BY KJB	DATE: 11/05/19
DESCRIPTION: STANDARD DRAWINGS.					CHK BY MCR	DATE: 11/05/19
ECN No. N/A					APP BY MCR	DATE: 11/05/19

1075 Saint John Street
Easton, PA 18042-6661
PH 610-330-9000 FAX 610-330-8510
www.hindlepowerinc.com

HINDLEPOWER

ATEVO BATTERY CHARGER
CONTROL PANEL / PC BOARD DETAIL
3Ø W/O OPTIONS 75-100A

B SCALE DWG No. **JE5333-02** REV 1 SHEET 1 OF 2

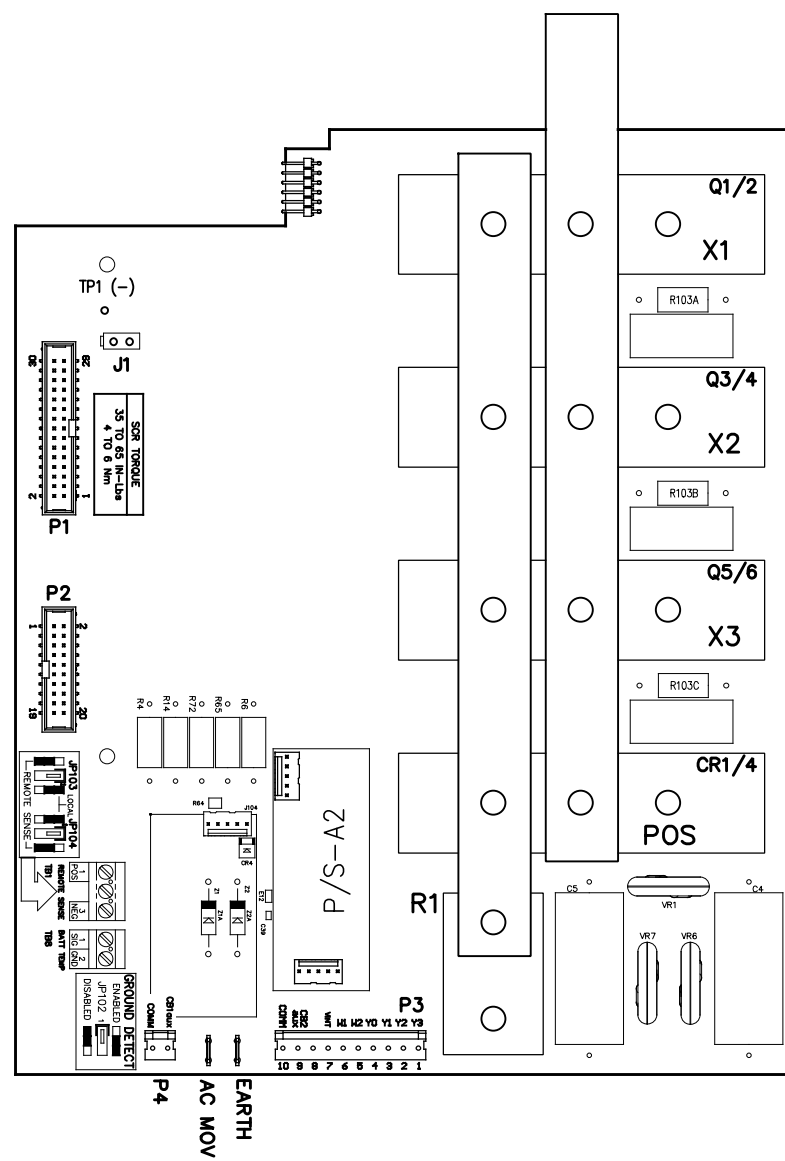

USER TERMINALS ON POWER BOARD (A2):
 TB1 - REMOTE VOLTAGE SENSE
 TB8 - BATTERY TEMPERATURE COMPENSATION

JUMPERS ON POWER BOARD (A2):
 JP102 - GROUND DETECT CIRCUIT ENABLE / DISABLE
 JP103 - REMOTE OR LOCAL SENSE SELECTOR (+)
 JP104 - REMOTE OR LOCAL SENSE SELECTOR (-)

CONNECTORS ON POWER BOARD (A2):
 J1 - POWER OUT
 J101 - DC POWER SUPPLY
 J102 - DC POWER SUPPLY
 J104 - BATTERY SHUNT
 J105 - AUXILIARY I/O BOARD
 P1 - MAIN CONTROL BOARD RIBBON 1
 P2 - MAIN CONTROL BOARD RIBBON 2
 P3 - Wx, Yx, CB2-AUX, VINT
 P4 - CB1-AUX

DISCRETE TERMINALS:
 AC MOV - CHASSIS EARTH GROUND
 EARTH - CHASSIS EARTH GROUND (DOOR)
 POS - POSITIVE CONNECTION POINT
 NEG - NEGATIVE CONNECTION POINT
 COMM - BREAKER AUX SWITCH COMMON
 X1 - TRANSFORMER SECONDARY WINDING
 X2 - TRANSFORMER SECONDARY WINDING
 X3 - TRANSFORMER SECONDARY WINDING
 L1-1 - FILTER INDUCTOR #1 (TERMINAL #1)
 L1-2 - FILTER INDUCTOR #1 (TERMINAL #2)

TEST POINTS ON POWER BOARD (A2):
 TP1 - PRE-FILTERED DC BUS (-)
 TP2 - PRE-FILTERED DC BUS (+)
 TP3 - DC BUS (-)
 TP4 - DC BUS (+)

NOTE:
 1. REMOTE SENSE JUMPERS (JP103, JP104) MUST BE IN REMOTE SENSE POSITION IN STYLE-5070 ENCLOSURE.

I/O TERMINAL	DESCRIPTION - TYPE	CONNECTION
(A2) TB1	POS/NEG REMOTE SENSE TERMS (A2) - SOLDERLESS COMPRESSION SCREW	#22-14 AWG
(A2) TB8	TEMPCO PROBE (A10) TERM BLK - SOLDERLESS COMPRESSION SCREW	#22-14 AWG

REV. 1	DRN BY KJB	CHK BY MCR	APP BY MCR	DATE 11/05/19	DRN BY KJB	DATE: 11/05/19
DESCRIPTION: STANDARD DRAWINGS.				CHK BY MCR	DATE: 11/05/19	
ECN No. N/A				APP BY MCR	DATE: 11/05/19	

1075 Saint John Street
 Easton, PA 18042-6661
 PH 610-330-9000 FAX 610-330-8510
 www.hindlepowerinc.com

HINDLEPOWER

TITLE
**ATEVO BATTERY CHARGER
 CONTROL PANEL / PC BOARD DETAIL
 3Ø W/O OPTIONS 75-100A**

B SCALE DWG No
 NTS JE5333-02

REV 1 SHEET 2 OF 2

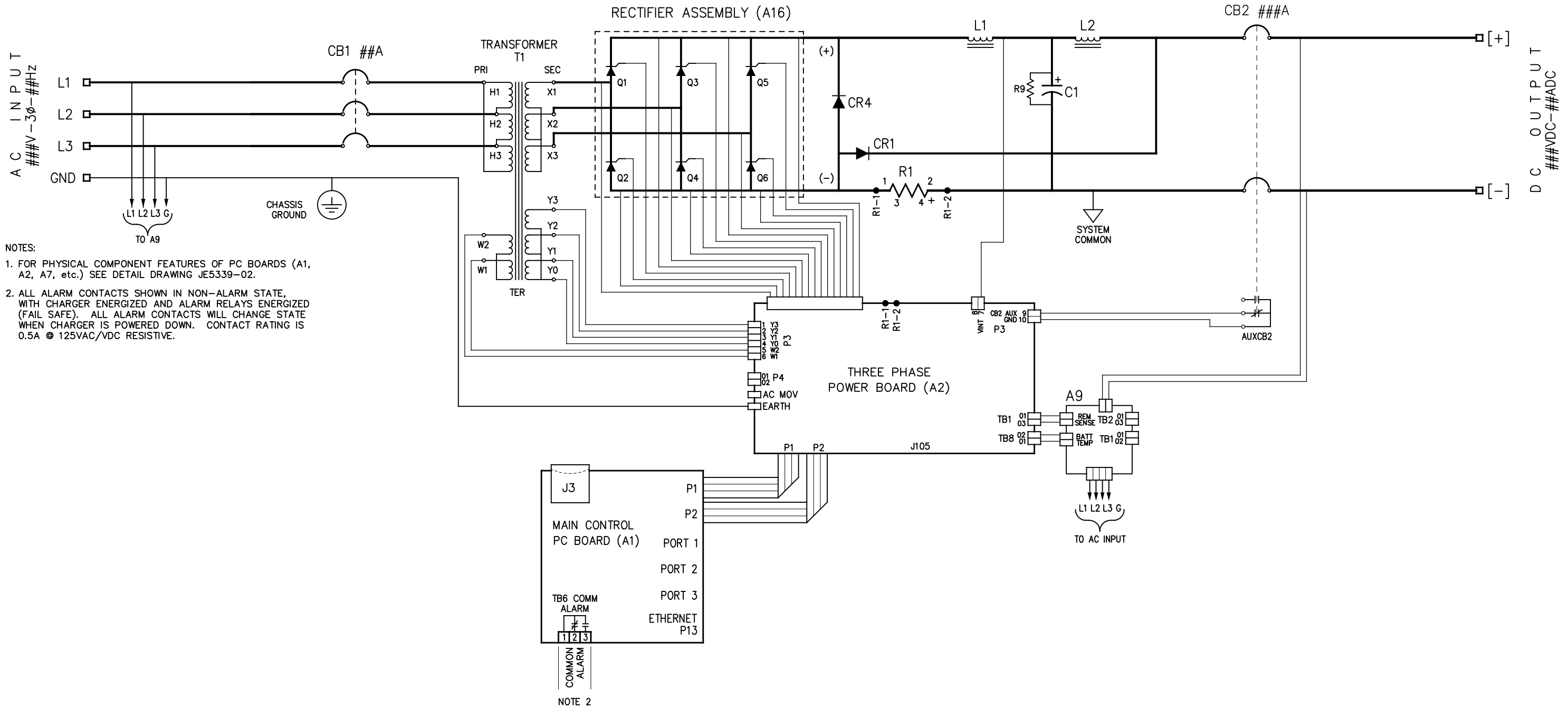

- NOTES:
1. FOR PHYSICAL COMPONENT FEATURES OF PC BOARDS (A1, A2, A7, etc.) SEE DETAIL DRAWING JE5339-02.
 2. ALL ALARM CONTACTS SHOWN IN NON-ALARM STATE, WITH CHARGER ENERGIZED AND ALARM RELAYS ENERGIZED (FAIL SAFE). ALL ALARM CONTACTS WILL CHANGE STATE WHEN CHARGER IS POWERED DOWN. CONTACT RATING IS 0.5A @ 125VAC/VDC RESISTIVE.

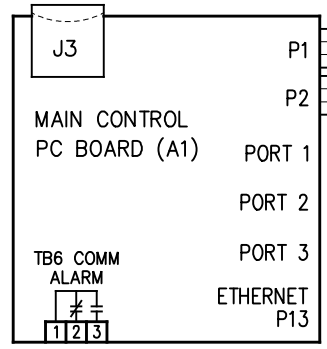

NOTE 2

REV. 2	DRN BY KJB	CHK BY MCR	APP BY MCR	DATE 1/27/2023	DRN BY KJB	DATE 11/05/19	<p>HINDLEPOWER</p> <p>1075 Saint John Street Easton, PA 18042-6661 PH 610-330-9000 FAX 610-330-8510 www.hindlepowerinc.com</p>
DESCRIPTION STANDARD DRAWINGS.					CHK BY MCR	DATE 11/05/19	
ECN No. N/A					APP BY MCR	DATE 11/05/19	
					TITLE ATEVO BATTERY CHARGER SCHEMATIC: STYLE 5070 3Ø W/O OPTIONS 75-100A		
					SCALE B	DWG No. JE5334-02	REV. 2
					SHEET 1 OF 1		

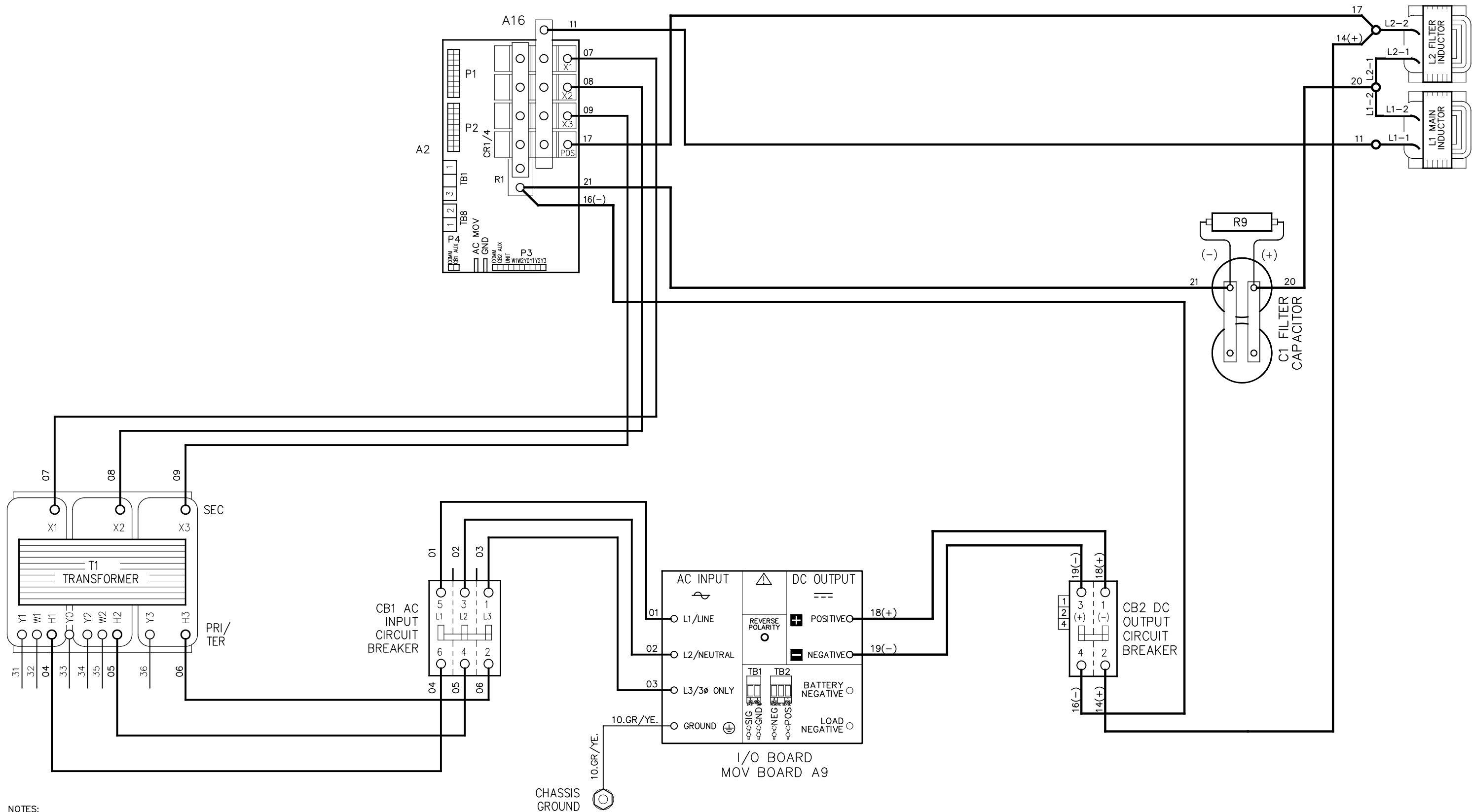

- NOTES:
1. WHEN NATURAL LEADS OF MAGNETICS ARE NOT USED, CHARGER COMPONENTS ARE CONNECTED WITH BLACK FLAME-RETARDANT SWITCHBOARD INSULATION SYSTEM (SIS) TYPE WIRING, IDENTIFIED ON EACH END WITH NUMBER-CODED MARKERS. GROUND WIRES ARE GREEN WITH YELLOW STRIPE.
 2. THIS DRAWING (SHEET 1) SHOWS THE MAINFRAME POWER WIRING AND USER CONNECTION CONTACTS TO CONTROL PC BOARDS (A1 & A2). SEE SHEET 2 FOR ALL CONTROL (SIGNAL) WIRING.

REV. 1	DRN BY KJB	CHK BY MCR	APP BY MCR	DATE 9/11/2023	DRN BY KJB	DATE: 11/05/19	<p>HINDLEPOWER</p> <p>1075 Saint John Street Easton, PA 18042-6661 PH 610-330-9000 FAX 610-330-8510 www.hindlepowerinc.com</p>
DESCRIPTION					CHK BY MCR	DATE: 11/05/19	
REVISED T1 SINGAL WIRING ORDER.					APP BY MCR	DATE: 11/05/19	
ECN No. N/A							
TITLE							<p>ATEVO BATTERY CHARGER CONN DIAGRAM: STYLE 5070 3ϕ W/O OPTIONS 75-100A</p>
SCALE DWG No							
<p>B NTS JE5335-02</p>							
REV 1 SHEET 1 OF 2							

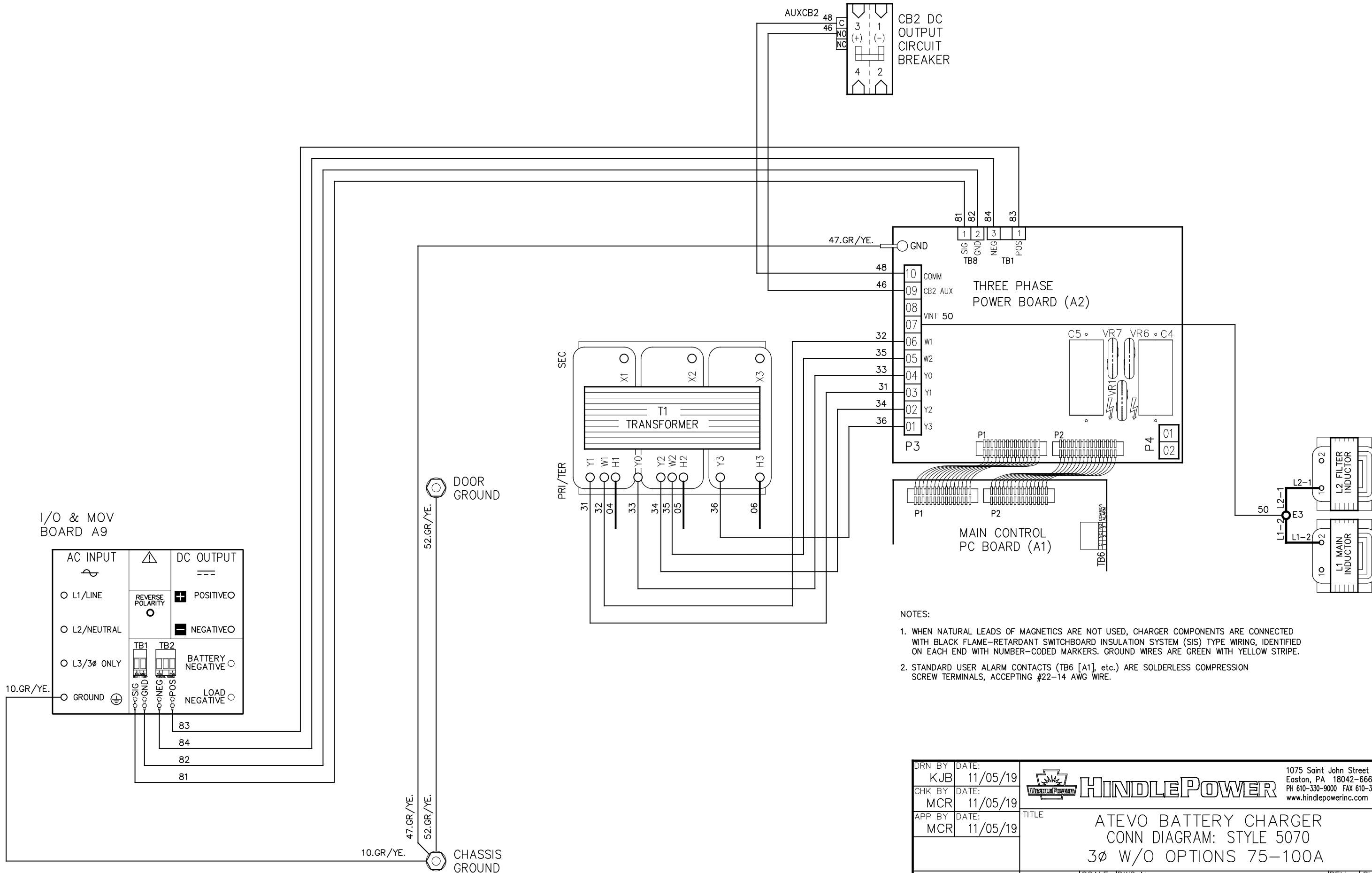

I/O & MOV BOARD A9

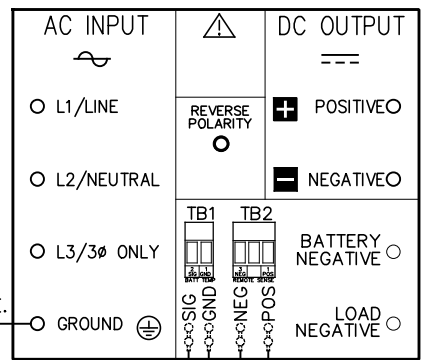

NOTES:

1. WHEN NATURAL LEADS OF MAGNETICS ARE NOT USED, CHARGER COMPONENTS ARE CONNECTED WITH BLACK FLAME-RETARDANT SWITCHBOARD INSULATION SYSTEM (SIS) TYPE WIRING, IDENTIFIED ON EACH END WITH NUMBER-CODED MARKERS. GROUND WIRES ARE GREEN WITH YELLOW STRIPE.
2. STANDARD USER ALARM CONTACTS (TB6 [A1], etc.) ARE SOLDERLESS COMPRESSION SCREW TERMINALS, ACCEPTING #22-14 AWG WIRE.

DRN BY	DATE:
KJB	11/05/19
CHK BY	DATE:
MCR	11/05/19
APP BY	DATE:
MCR	11/05/19

HINDLEPOWER
 1075 Saint John Street
 Easton, PA 18042-6661
 PH 610-330-9000 FAX 610-330-8510
 www.hindlepowerinc.com

TITLE
ATEVO BATTERY CHARGER
 CONN DIAGRAM: STYLE 5070
 3φ W/O OPTIONS 75-100A

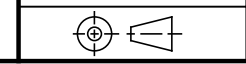

B	SCALE	DWG No	REV	SHEET
NTS		JE5335-02	1	2 OF 2