

DESIGN NOTES:

- ENCLOSURE IS A NEMA-3R TYPE CABINET WITH GASKETING AND FOAM INJECTED PANELING. FINISH IS ANSI 61 GREY POWDERCOAT.
- HINGES MADE OF STAINLESS STEEL GRADE 316
- CONDUIT ENTRY PROVIDED THROUGH SIDE PANEL 10.5in BY 1.4in GLAND PLATE AVAILABLE FOR KNOCKOUT. SEE FOUNDATION DRAWINGS (JE5276-54) FOR KNOCKOUT LOCATIONS. CONDUIT ACCESS ALSO AVAILABLE FROM UNDERNEATH CABINET.
- LOCATE UNIT ONTO A PERMANENT, FLAT, AND LEVELED SURFACE, PREFERABLY CONCRETE OR OTHER FIREPROOF MATERIAL. SURFACE MUST BE CAPABLE OF SUPPORTING WEIGHT OF COMPLETE SYSTEM AND INSTALLED COMPONENTS. SEE FOUNDATION DRAWING (JE5276-54) FOR LOADING INFORMATION.
- VENTILATION AND THERMAL MANAGEMENT OF BATTERIES PER IEEE 1635. SEISMIC CERTIFICATION PER IEEE 693.
- THE WEIGHT OF THE CONSOLE WITHOUT BATTERIES IS 1705lb [773kg]
- FOR LIFTING, USE OPTIONAL STRAPPING SYSTEM (SEE E15196-02).

REV	DRN BY	CHK BY	APP BY	DATE	DRN BY	DATE	CHK BY	DATE	APP BY	DATE	TITLE							
B	KJB	RCF	RCF	05/01/24	KJB	05/01/24	RCF	05/01/24	RCF	05/01/24	EPIC SERIES 2.0 CONSOLE							
DESCRIPTION UPDATED DESIGN																		
UNLESS OTHERWISE SPECIFIED: ALL DIMENSIONS TO CENTER UNLESS NOTED OTHERWISE TOLERANCES ARE: DIMS: ±.004 DIMS: > 1.000: ±.015 DIMS: > 2.500: ±.031																		
<table border="0"> <tr> <td>SCALE</td> <td>1:13</td> <td>DWG No</td> <td>JE5269-54</td> <td>REV</td> <td>B</td> <td>SHEET</td> <td>1 OF 1</td> </tr> </table>											SCALE	1:13	DWG No	JE5269-54	REV	B	SHEET	1 OF 1
SCALE	1:13	DWG No	JE5269-54	REV	B	SHEET	1 OF 1											

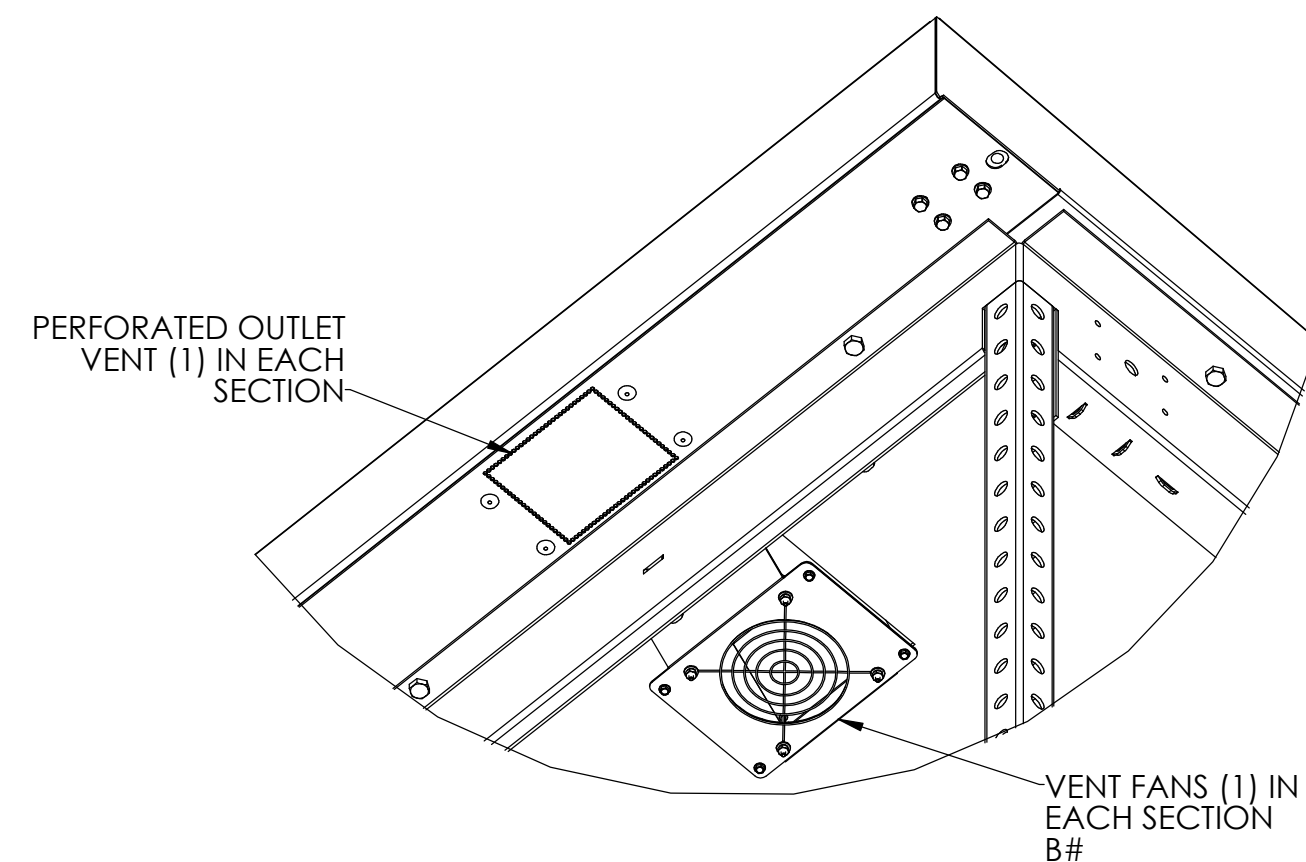
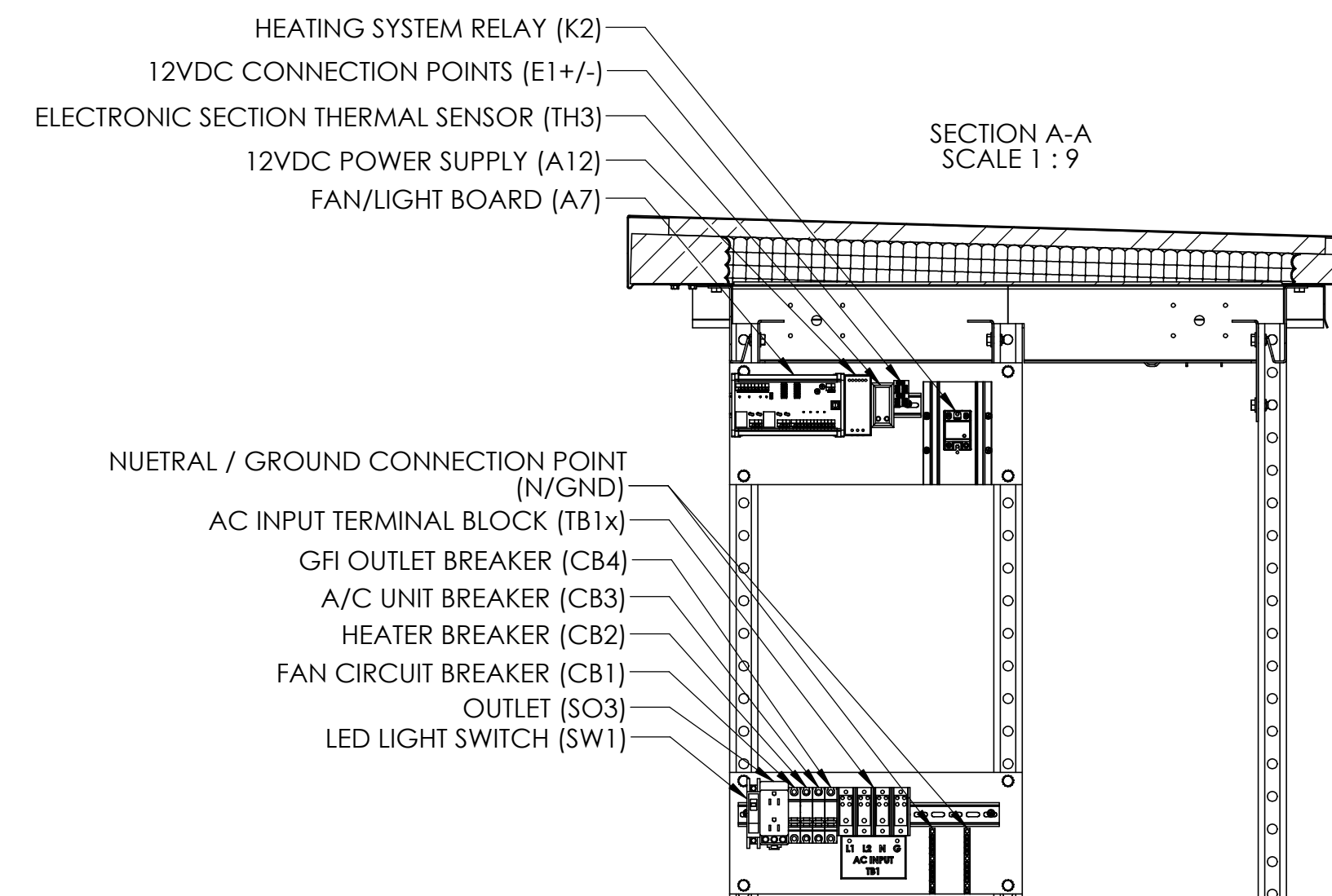
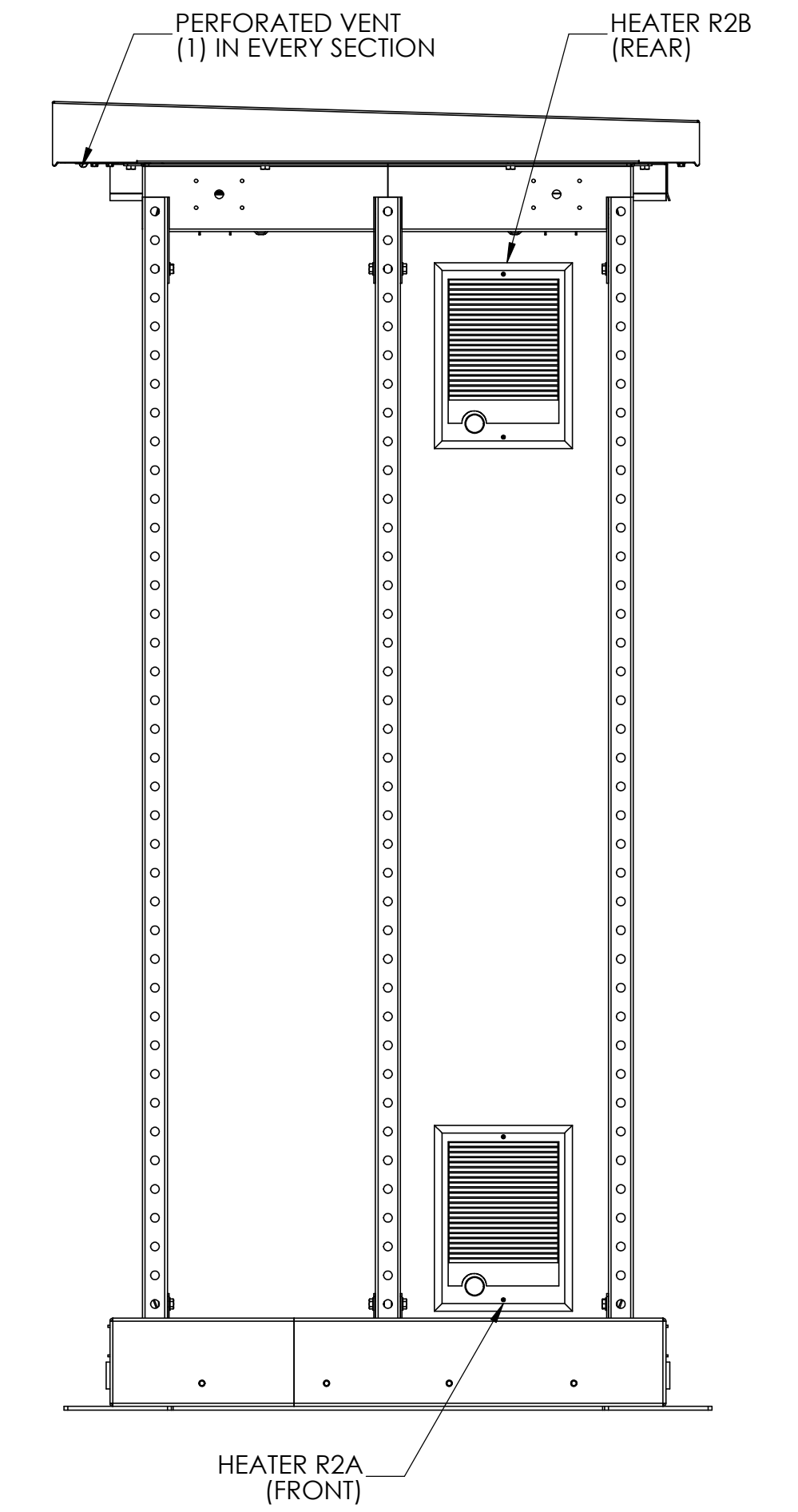
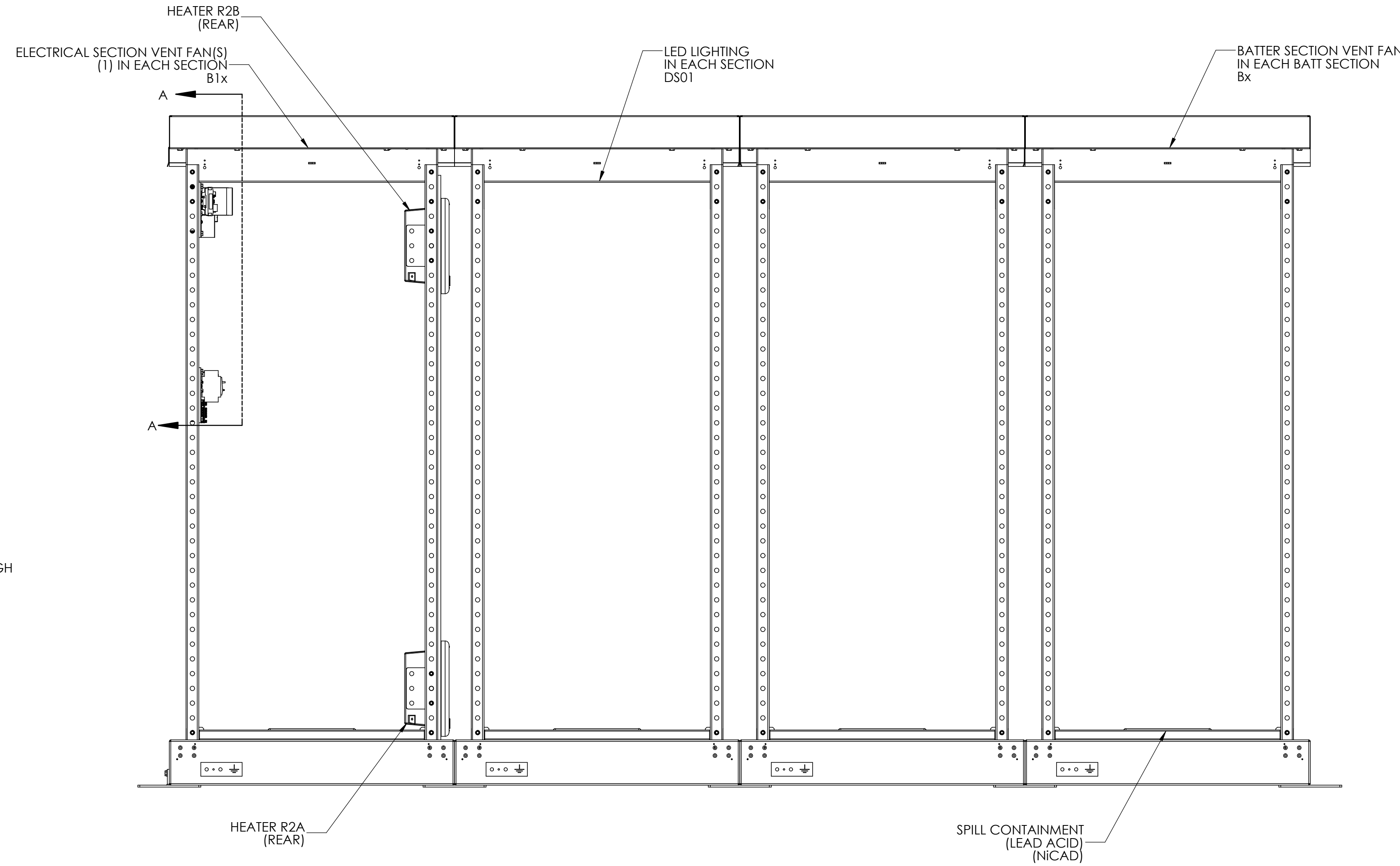
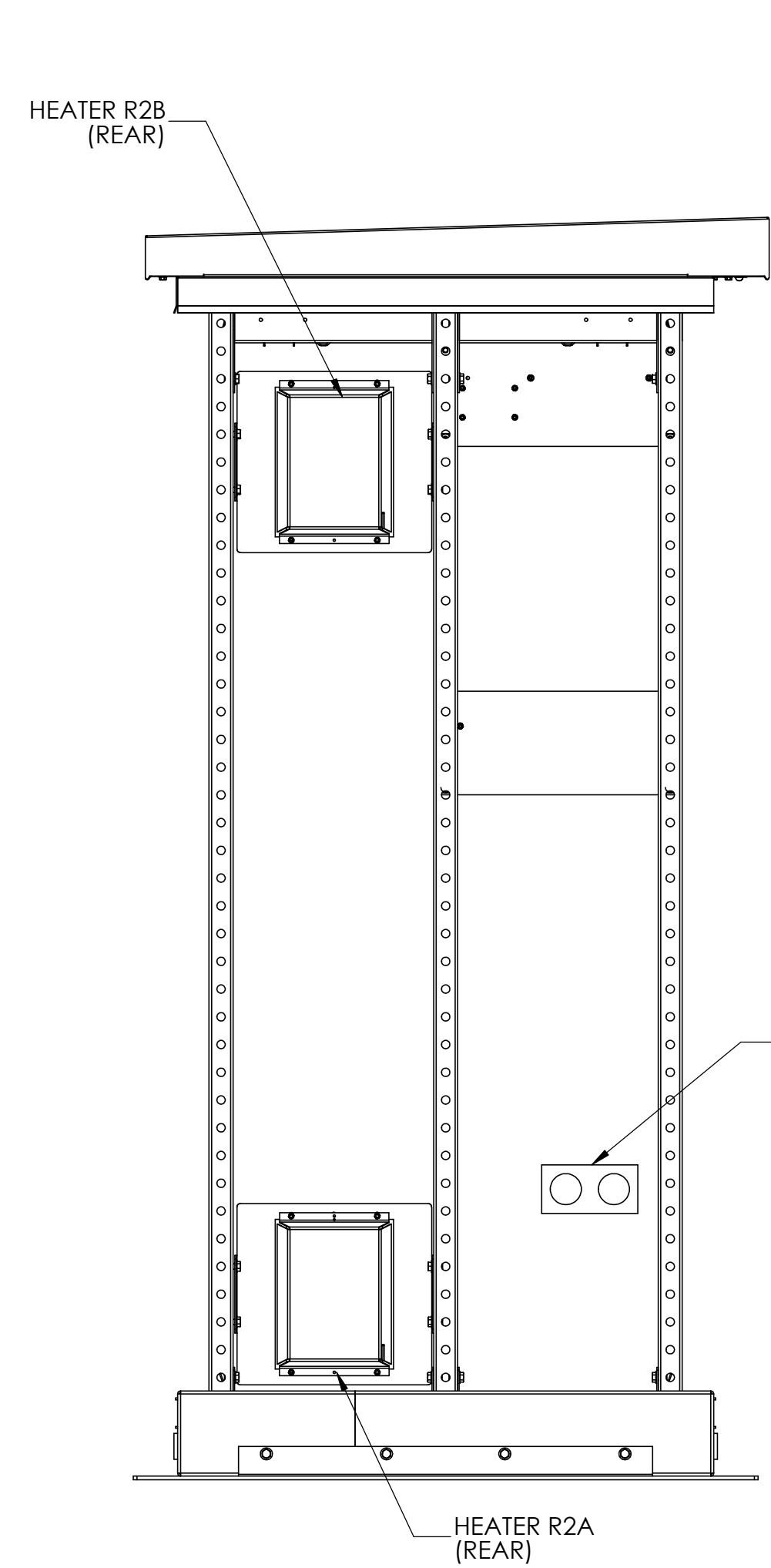

FAN AND LIGHT BOARD (A7) ALARM INDICATOR LEADS	
LED	ALARM DESCRIPTION
INPUT 1	HVAC ALARM
INPUT 2	Available
INPUT 3	Available
INPUT 4	Available
FAN 1	FAIL
FAN 2	ON

SEE MANUAL FOR MORE DETAIL ON ALARM INPUTS

- NOTES:
- TO PROVIDE A CLEAR VIEW OF THE CONSOLE INTERNAL COMPONENTS, THE FOLLOWING ITEMS ARE NOT SHOWN:
    - FRONT DOORS W/ EYE WASH
    - REAR PANELS/DOORS
    - LEFT AND RIGHT SIDE PANELS
  - DO NOT LIFT, PUSH OR RELOCATE THE EPIC CONSOLE WITH BATTERIES INSTALLED WITHIN ENCLOSURE.
  - BATTERY TYPE: ## (# JARS)

REV   DRN BY   CHK BY   APP BY   DATE	DRN BY   DATE		<b>EPIC SERIES 2.0 CONSOLE</b> INTERNAL LAYOUT: 1 ELEC. / 1 BATT. SALES ORDER No. N/A
B   KJB   RCF   RCF   05/01/24	KJB   05/01/24		
DESCRIPTION	CHK BY   DATE	<small>UNLESS OTHERWISE SPECIFIED ALL DIMENSIONS FOLLOW THE ANSI OVER SIZE (INCHES) POUNDS &amp; SECONDS (IPSS) STANDARD (DEC 2 1975) UNLESS OTHERWISE SPECIFIED</small>	
UPDATED DESIGN	RCF   05/01/24	SCALE   DWG No.   REV   SHEET 1:10   D   1:10   JE5270-54   B   1 OF 1	

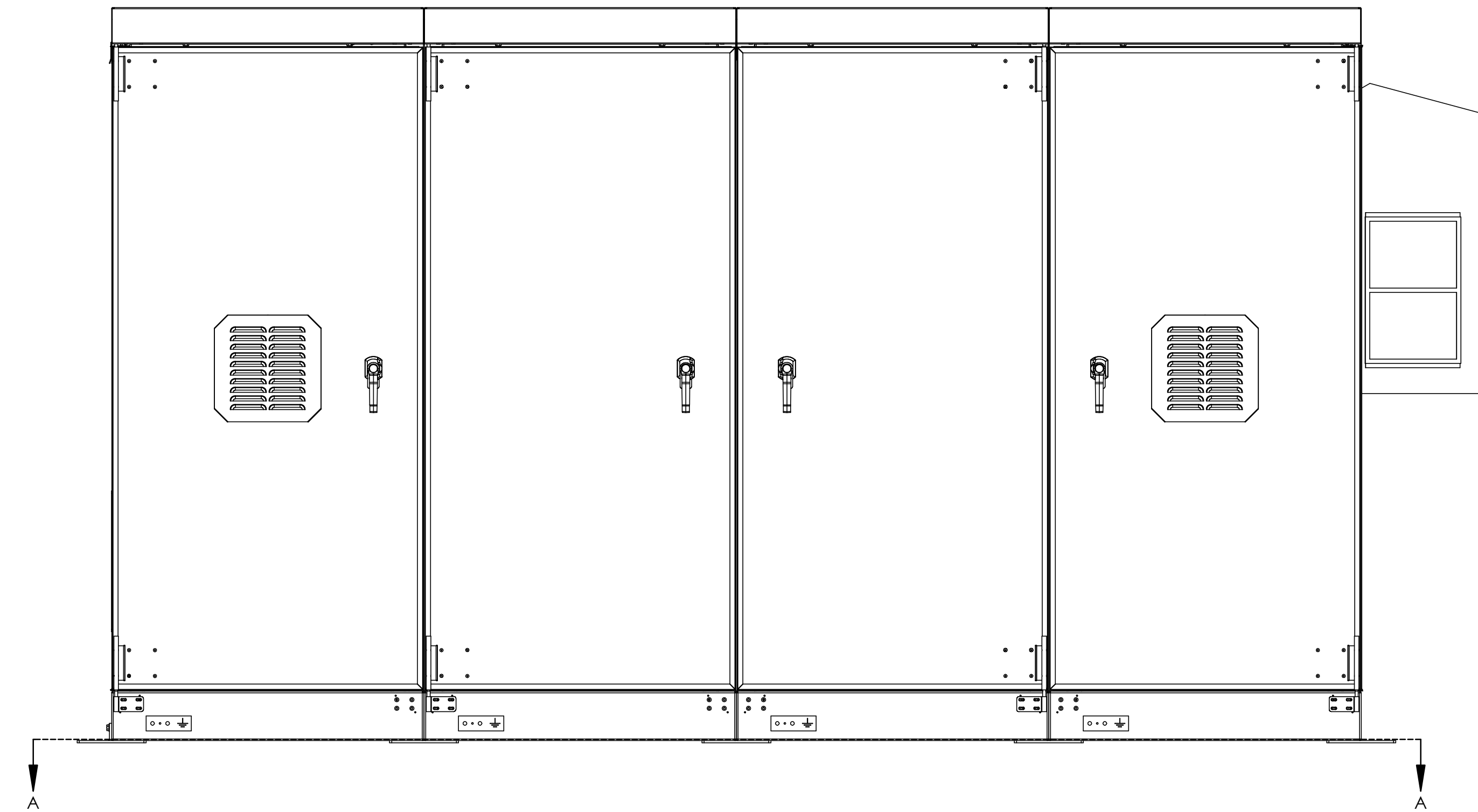
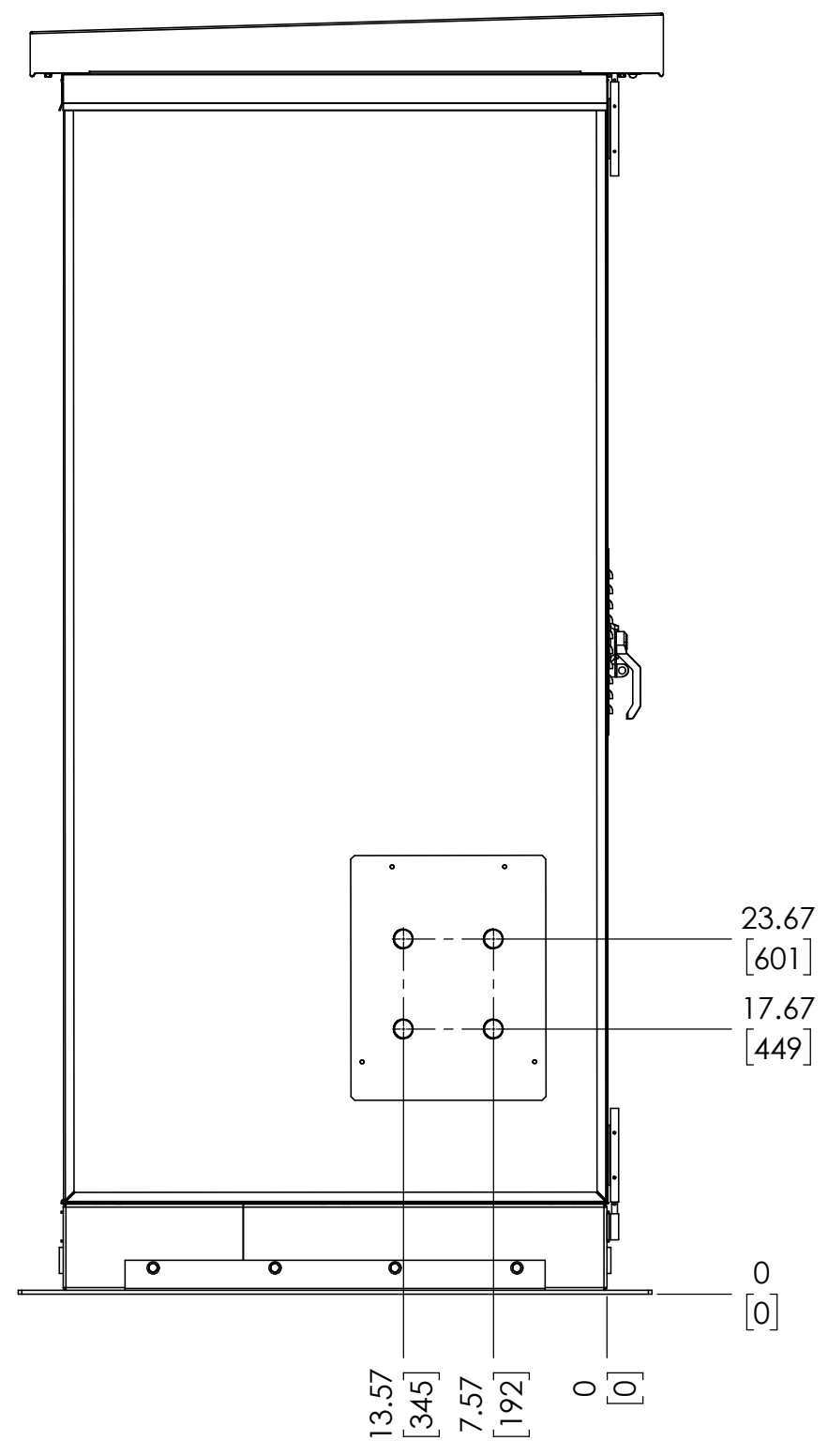

NOTE 2

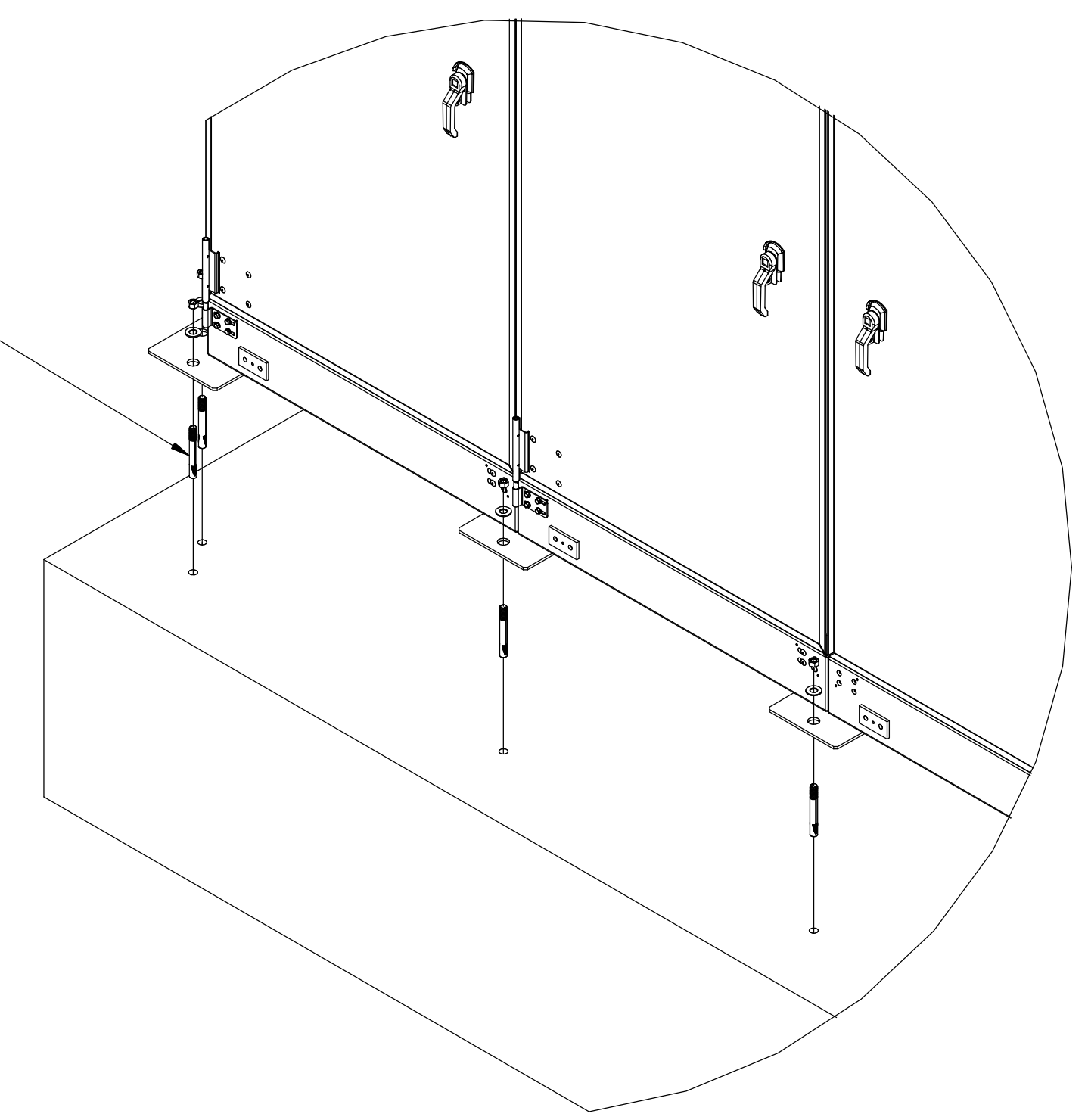

SECTION A-A  
MOUNTING DIMENSIONS

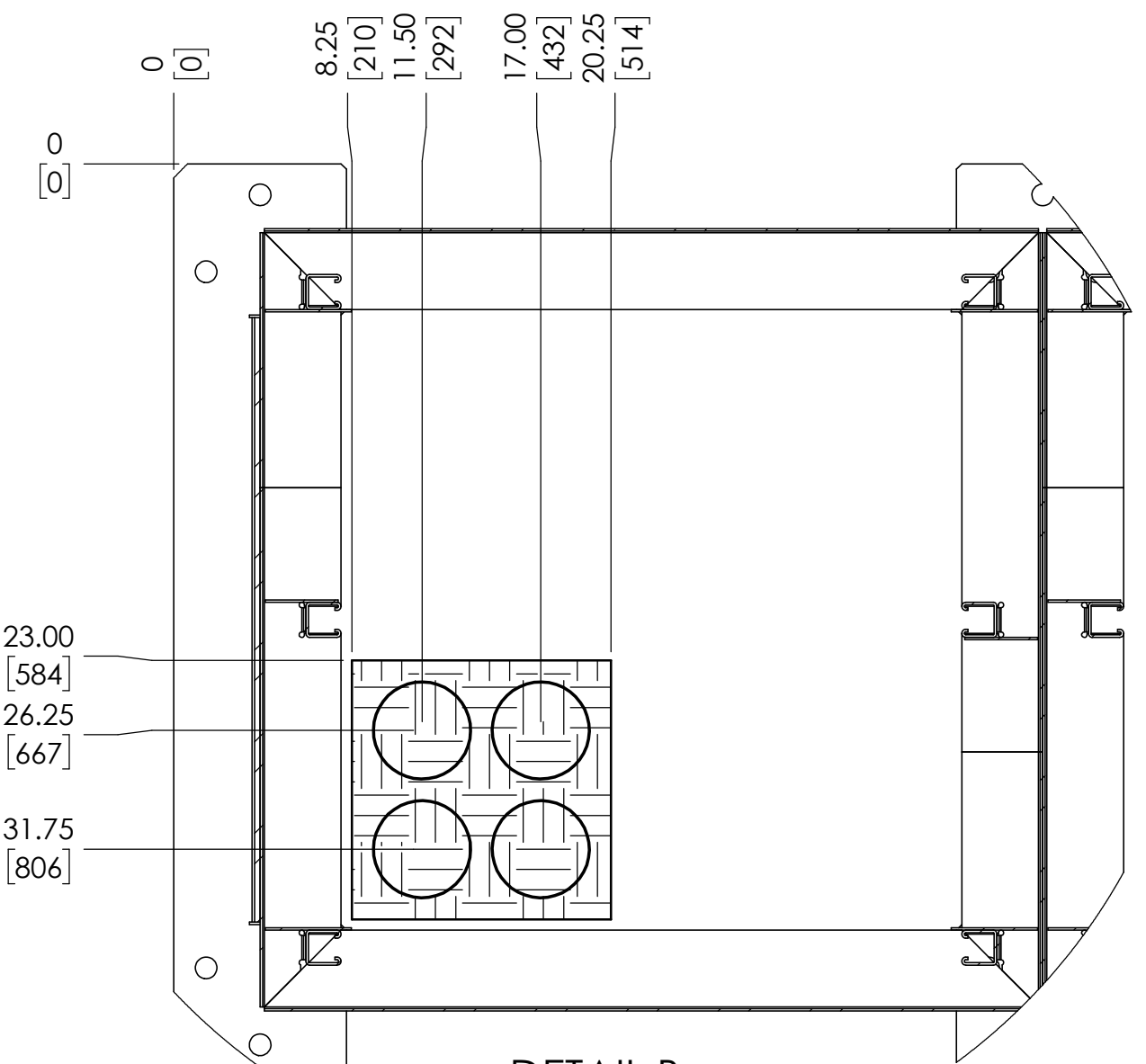
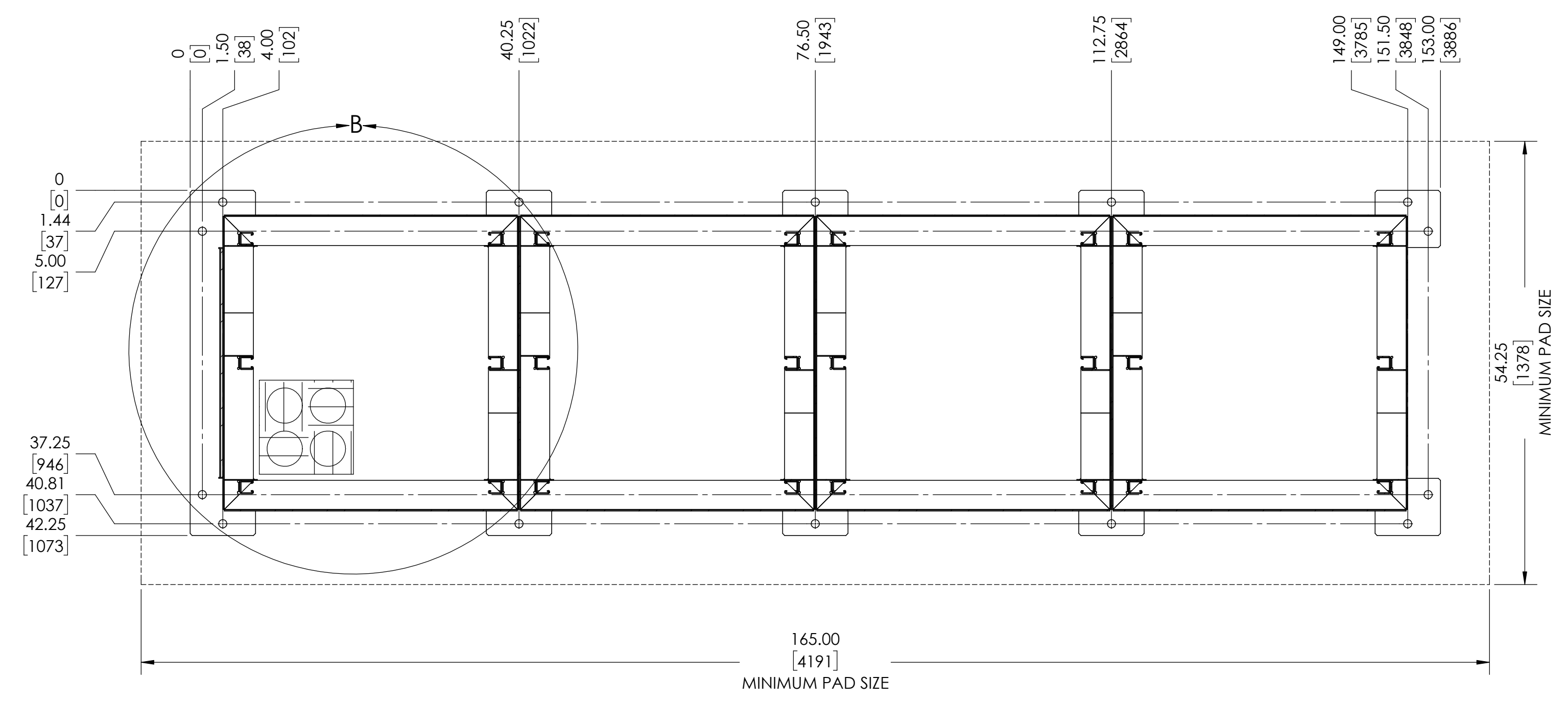

DETAIL B  
SCALE 1:8

NOTES:

1. MOUNTING DIMENSIONS SHOWN ON DRAWING ARE FINAL. WE RECOMMEND PLACING CONSOLE, THEN DRILLING FOR MOUNTING ANCHORS.
2. ANCHOR BOLTS ARE TO BE HILTI M12 HDA-TR STAINLESS STEEL UNDERCUT (OR EQUIVALENT). HOLE DEPTH TO BE MINIMUM OF 5.3" [135mm], PAD DEPTH TO BE MINIMUM OF 8.0" [203mm]
3. CONCRETE PAD TO EXTEND A MINIMUM OF 6" [153mm] FROM EDGE OF CABINET ON ALL SIDES. SEE MOUNTING DIMENSIONS BELOW. THE WEIGHT OF THE CONSOLE WITH BATTERIES (SPECIFIED IN PURCHASE ORDER) IS 1750lb [794kg]
4. CONCRETE PAD TO BE 4000 psi OR GREATER.
5. ELECTRICAL CONDUIT MAY ENTER FROM UNDERNEATH CABINET, BUT ONLY THROUGH LOCATIONS SHOWN IN DETAIL B.
6. CONDUIT ENTRY PROVIDED THROUGH SIDE PANEL 10.5in BY 14in GLAND PLATE AVAILABLE FOR KNOCKOUT. KNOCKOUTS MAY NOT BE VISIBLE, USE DIMENSIONS TO VERIFY BREAKAWAY POINTS.

REV   DRN BY   CHK BY   APP BY   DATE	DRN BY   DATE		<small>© 2015 HandlePower, Inc. All rights reserved. HandlePower.com</small>
B   KJB   RCF   RCF   05/01/24	KJB   05/01/24		
DESCRIPTION	CHK BY   DATE	<b>EPIC SERIES 2.0 CONSOLE</b>	
UPDATED DESIGN	RCF   05/01/24	<b>FOUNDATION DRAWINGS</b>	
	APP BY   DATE	SALES ORDER No. N/A	
	RCF   05/01/24	<small>UNLESS OTHERWISE SPECIFIED ALL DIMENSIONS FOLLOW THE ANSI SYSTEM OF UNITS (INCHES-FRACTIONS &amp; DECIMALS) TOLERANCES UNLESS OTHERWISE SPECIFIED: DEC + 0.00, ANG ± 0.2°</small>	
		SCALE   DWG No.	REV   SHEET
		1:12	D   B   1 OF 1

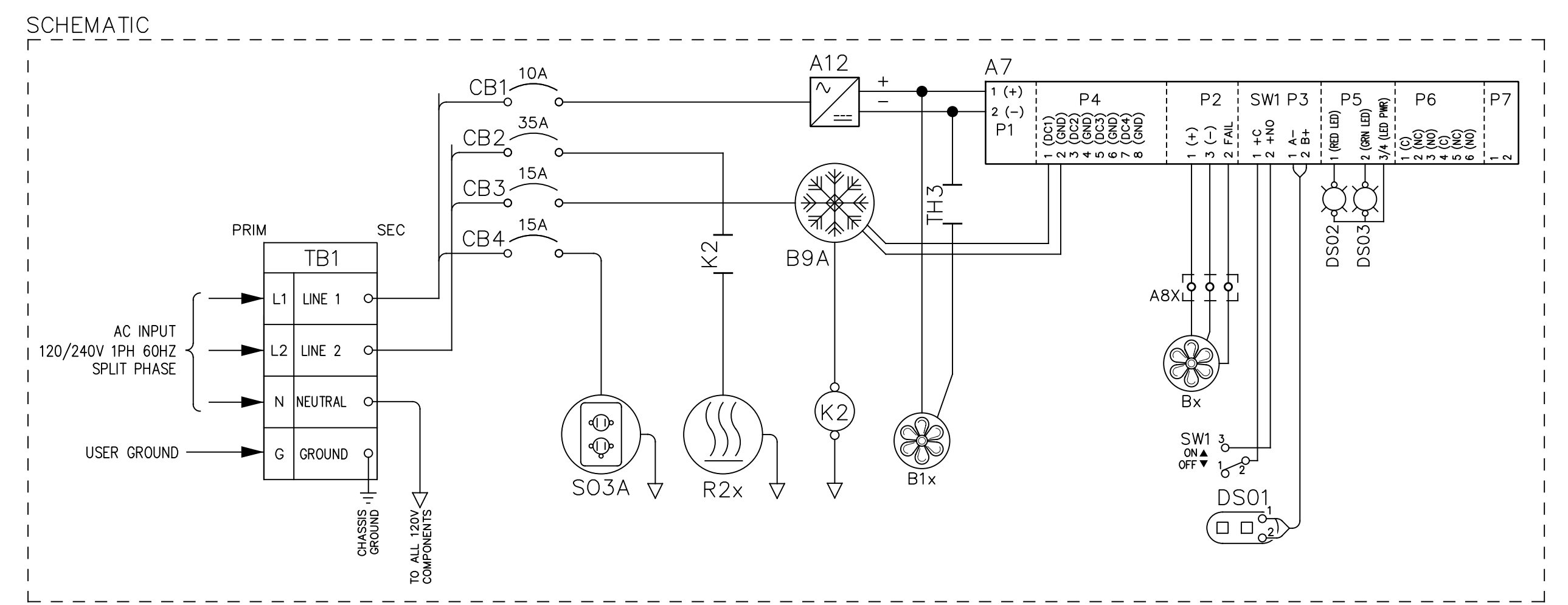
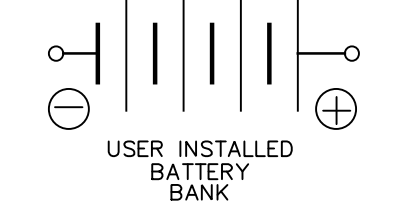
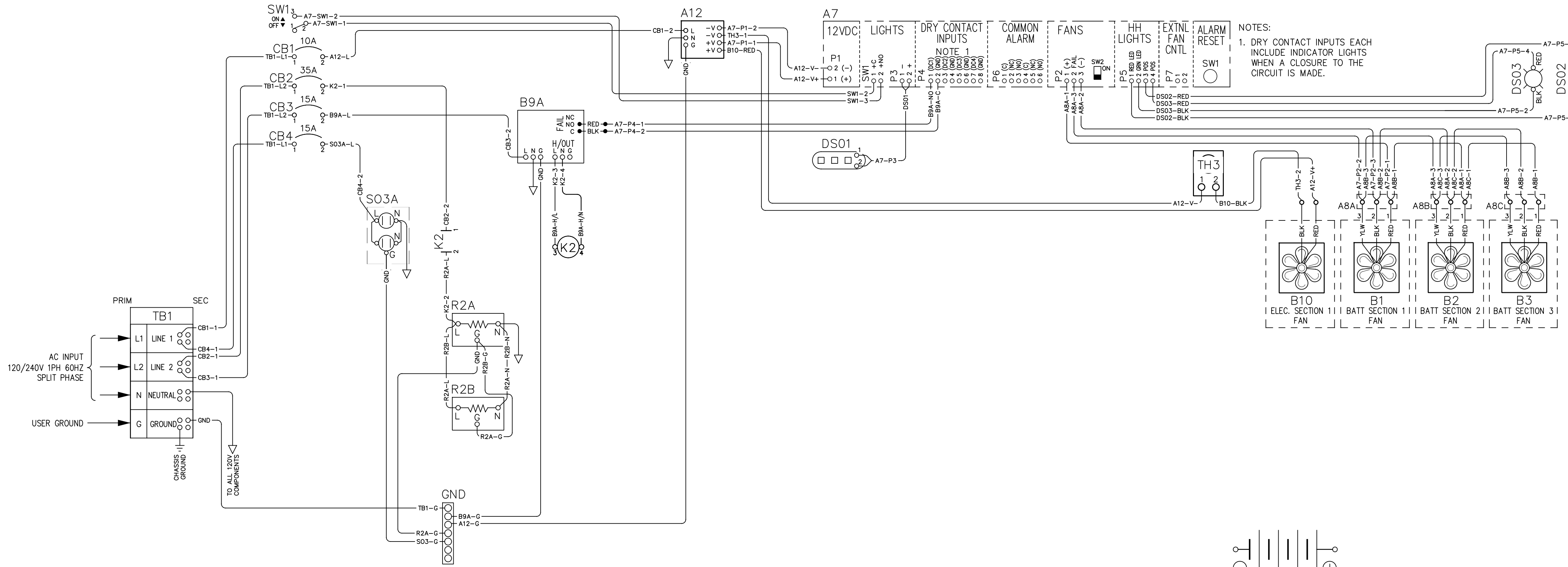

EPIC SERIES COMPONENTS

SYMBOL	DESCRIPTION
A7	FAN/LIGHT BOARD
A8x	FAN BOARD(S)
A12	12VDC POWER SUPPLY
B9x	AIR CONDITIONING UNIT(S)
Bx	BATTERY SECTION VENT FANS
B1x	ELECTRIC SECTION VENT FANS
CB1	CIRCUIT BREAKER FOR A12 P/S
CB2	CIRCUIT BREAKER FOR HEATER
CB3	CIRCUIT BREAKER FOR AIR CONDITIONER
CB4	CIRCUIT BREAKER FOR GFI OUTLET
DS01	CONSOLE LED LIGHTS
DS02	RED LED
DS03	GREEN LED
E2	HEAT AND AC TERMINAL BLOCK
K2	HEATER SYSTEM RELAY
R2x	HEATER
SO3x	15A GFI OUTLET(S)
SW1	CONSOLE LED LIGHT SWITCH
TB1	AC INPUT TERMINAL BLOCK
TH3	ELECTRONIC SECTION THERMAL SENSOR

LEGEND FOR EPIC LINE

SYMBOL	DESCRIPTION
○	DEVICE TERMINAL
○	TERMINAL BLOCK POINT IN TRANSFORMER
○	TERMINAL BLOCK POINT FOR SCADA
○	TERMINAL BLOCK POINT FOR COMMUNICATIONS
○	TERMINAL BLOCK POINT IN POWER CIRCUIT BREAKER
▲	TERMINAL IN A.C. OR D.C. PANELBOARD
—	SHIPPED WITH WIRING INSTALLED
- - -	WIRING TO BE INSTALLED

I/O TERMINAL	DESCRIPTION - TYPE	CONNECTION
TB1 PRIM	L1, L2, AC INPUT / USER NTRL, GND TERMINALS - CU-ALUMINUM COMP LUG	(1) 2/0-#14 AWG
TB1 SEC	LINE 1, LINE 2 AC INPUT / USER NTRL, GND TERMINALS - CU-ALUMINUM COMP LUG	(4) #4-#14 AWG

REV: 10/18/2024	DRN BY: KJB	DATE: 10/18/21	CHK BY: CMF	DATE: 10/18/21	APP BY: RCF	DATE: 10/18/21		1075 Soltz John Street Easton, PA 18042-6661 PH 610-330-9000 FAX 610-330-8810 www.hindlepowerinc.com
DESCRIPTION: STANDARD DRAWINGS TITLE: EPIC SERIES 2.0 CONSOLE CONNECTION DIAGRAM: 1 ELEC. SECTION 3 BATT SECTION SALES ORDER NO. N/A							SCALE: DWG NO: JE5272-54 SHEET: 1 OF 1	