

ASSEMBLY PROCEDURE:

BEFORE YOU START:

- 1) FOLLOW ALL SAFETY AND QUALITY PROCESSES REQUIRED BY YOUR COMPANY.
- 2) DO YOU HAVE THE CORRESPONDING BOM FOR THE ASSEMBLY BEING BUILT?
- 3) DO YOU HAVE ALL THE PARTS LISTED ON THE BILL OF MATERIAL (BOM)?
- 4) NUMBERED BALLOONS CORRESPOND TO THE SEQUENCE No. ON THE BOM.

SHOWN BELOW IS A FRONT-RIGHT PERSPECTIVE VIEW OF YOUR EXISTING NEMA-1 TYPE STYLE-4 / STYLE-163 BATTERY CHARGER ENCLOSURE.

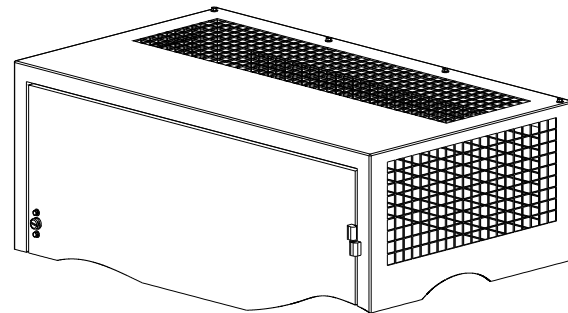

SHOWN BELOW IS A PARTIAL UPPER VIEW OF THE RIGHT ENCLOSURE SIDE.

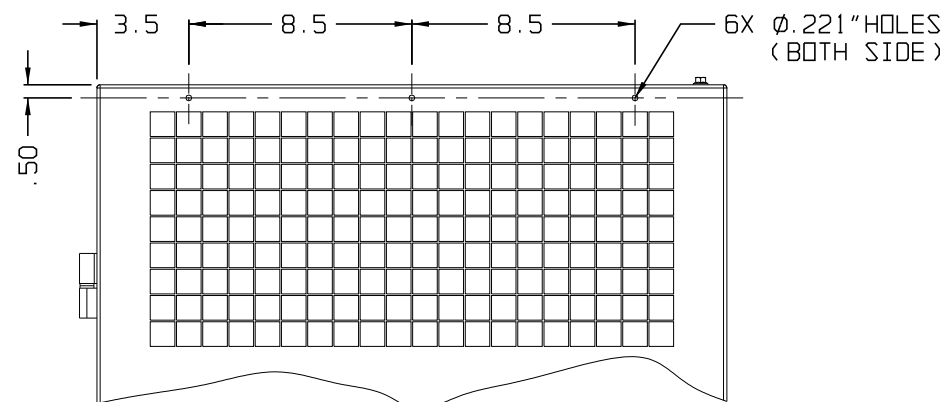

STEP 1) DRILL SIX (6) 0.221in / 5.6mm HOLES AS SHOWN ABOVE (PATTERN MIRRORED ON LEFT SIDE).

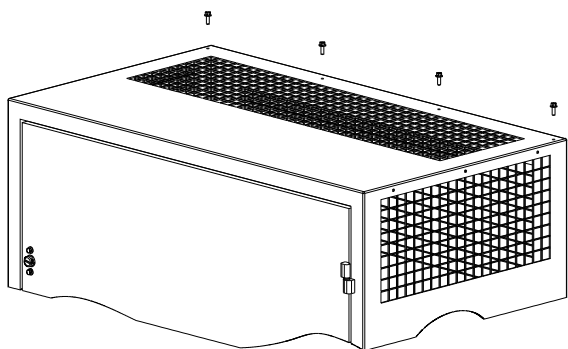

STEP 2) REMOVE THE FOUR (4) SCREWS THAT SECURE THE TOP PANEL ALONG THE BACK, AND SAVE THIS HARDWARE FOR STEP 3.

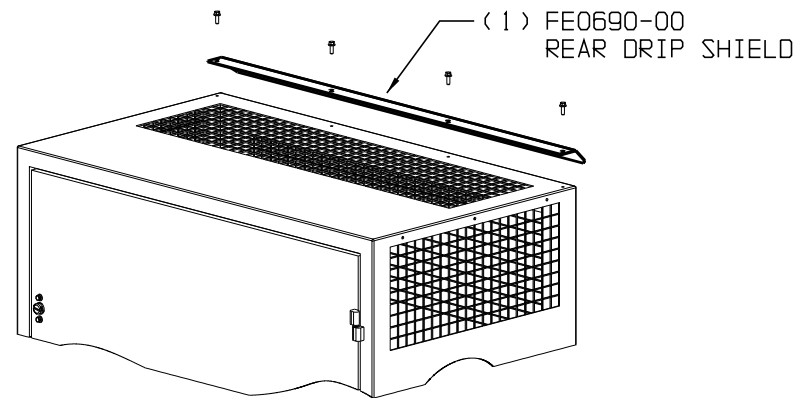

STEP 3) INSTALL AND SECURE THE REAR DRIP SHIELD AS SHOWN, USING THE SCREWS LISTED IN STEP 2.

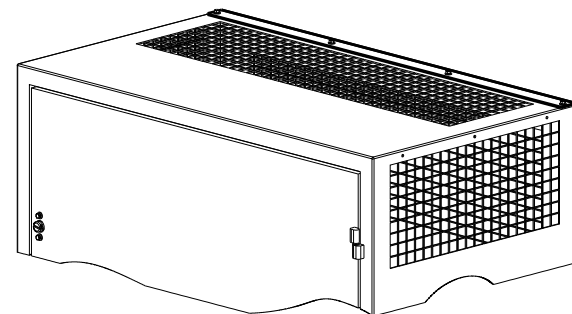

SHOWN ABOVE IS A WHAT YOUR REAR DRIP SHIELD (AFTER INSTALLED) SHOULD APPEAR LIKE

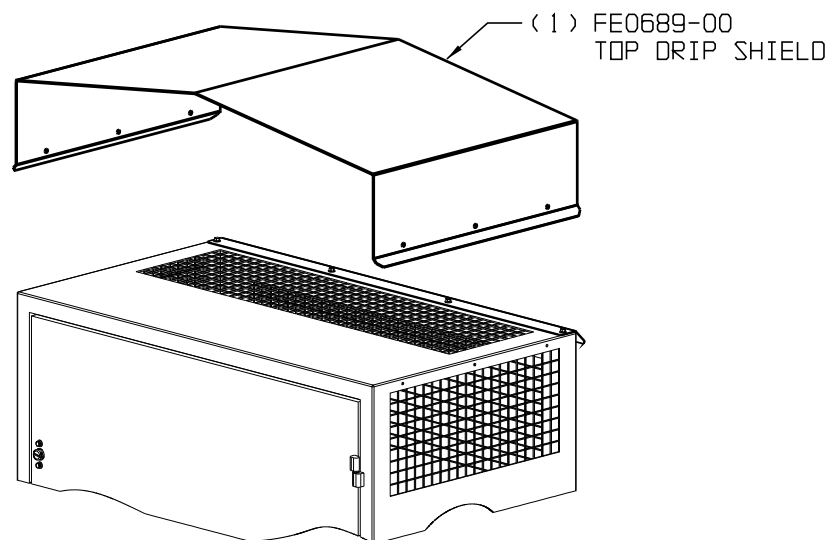

STEP 4) ALIGN THE TOP DRIP SHIELD COVER MOUNTING HOLES WITH THE TOP SIDE HOLES OF THE STYLE-4 / STYLE-163 ENCLOSURE.

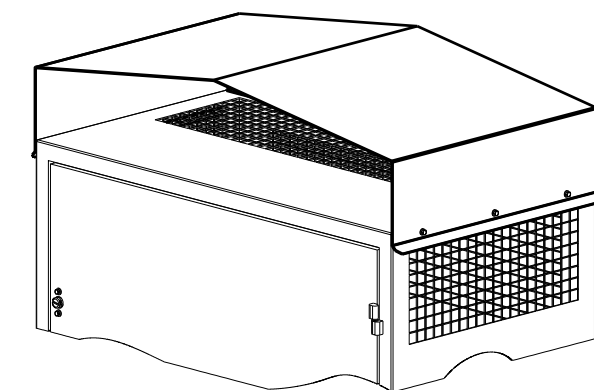

STEP 5) SECURE THE TOP DRIP SHIELD WITH THE SIX (6) SCREWS PROVIDED. CHECK AND INSPECT YOUR WORK.

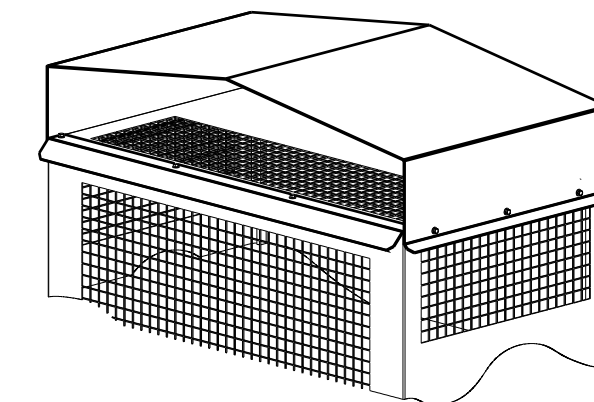

SHOWN ABOVE IS A REAR VIEW OF THE STYLE-4 / STYLE-163 NEMA-1 TYPE ENCLOSURE WITH THE NEMA-2 TYPE DRIP SHIELD FULLY INSTALLED

| | | | | | | |
|-----|--------|--------|--|-----|---|-------------------|
| | | | THIRD ANGLE PROJECTION | | 1075 Saint John Street Easton, PA 18042-6661 PH 610-330-9000 FAX 610-330-8510 www.hindlepowerinc.com | |
| | | | DRAWN BY <i>QA</i> 062223 ELECTRONIC APPROVAL SIGNATURES MAINTAINED BY MFG ECN LOG | | TITLE FIELD INSTALLATION INSTRUCTIONS FOR DRIP SHIELD ASSY: ATevo STYLE-163 ENCLOSURE | |
| 0 | -N/A- | 062223 | UNLESS OTHERWISE NOTED DIMENSIONS ARE IN INCHES. TOLERANCES ARE: | | DRAWING No JA0092-54 | REV 0 B |
| REV | ECN No | DATE | SCALE | NTS | PART No JA0092-54 | SHEET 1 OF 1 |