

SEE DRAWING  
JE5253-21

NOTE 3

NOTE 5

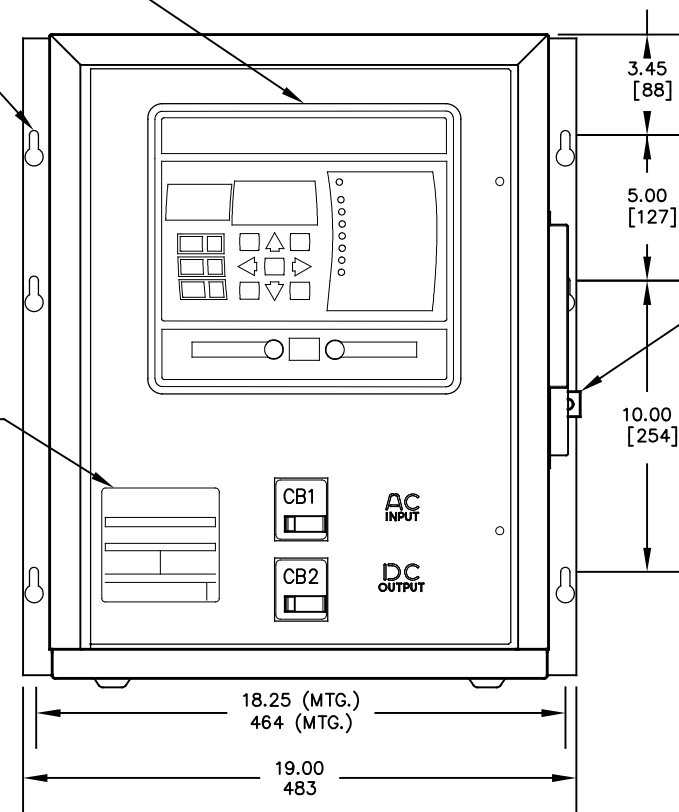

NOTE 7

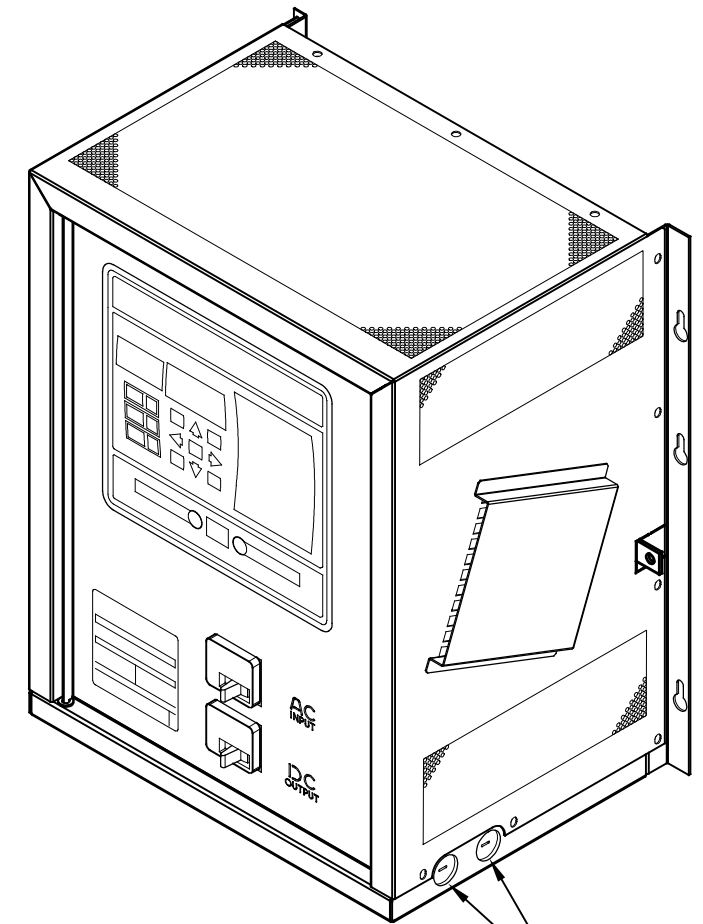
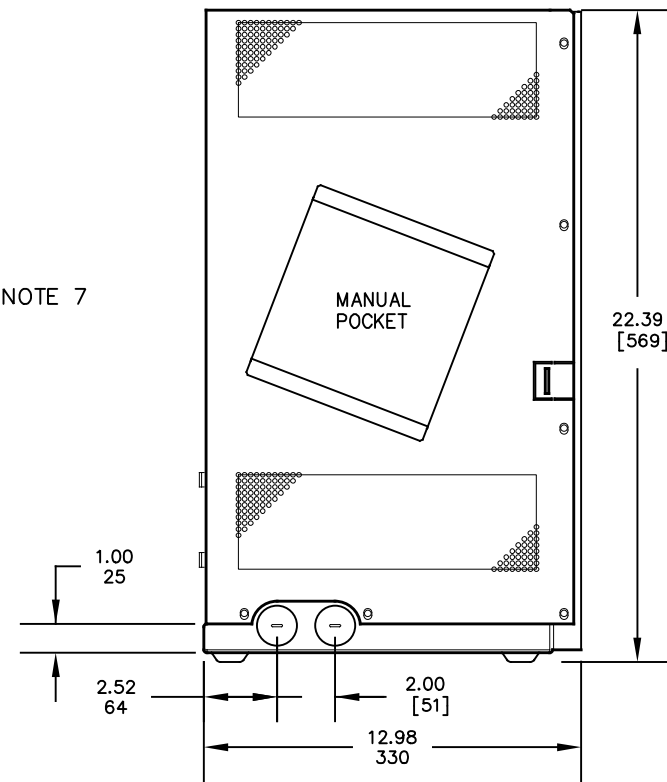

NOTE 4

NOTE 4

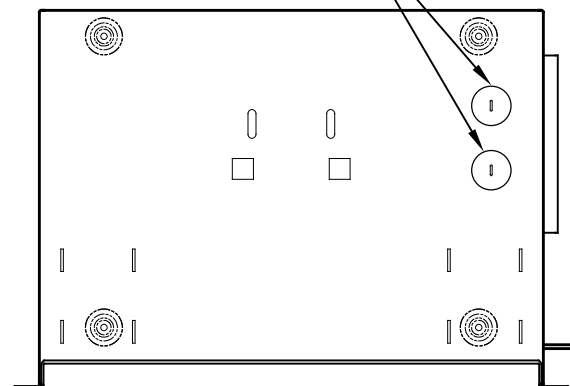

NOTES:

1. ENCLOSURE IS A NEMA TYPE 1 / IP20 TOP-VENTED STEEL CABINET WITHOUT GASKETS. FINISH IS ANSI-61 GRAY EPOXY POWDERCOAT. BASE IS 14 GA. SHROUD IS 18 GA. DOOR IS 16 GA.
2. ALLOW 6in / 152mm OF FREE AIR ON ALL VENTED SURFACES (TOP, SIDES & REAR) FOR COOLING.
3. SIX (6) KEY-HOLE SLOTS ARE PROVIDED ON BACK OF ENCLOSURE AS SHOWN. FOR WALL-MOUNTING WITH 0.25in / 6.25mm HARDWARE.
4. SIX (6) 1.31in / 33mm DIA KNOCKOUTS ARE PROVIDED AS SHOWN, WITH TWO (2) ADDITIONAL KNOCKOUTS FEATURED ON BOTTOM PANEL OF ENCLOSURE. USE OF ANY OF THESE FOUR (4) LOWER CONDUIT KNOCKOUTS WILL ALLOW REMOVAL OF CABINET SHROUD WITHOUT REMOVAL OF EXTERNAL WIRING.
5. DATA NAMEPLATE DECAL (WITH CHARGER RATINGS) APPLIED TO DOOR.
6. BATTERY CHARGER SHIPPING WEIGHT: SEE PRODUCT LITRITURE.
7. GROUND BUS BAR WITH 0.375 in / 9.52 mm DIA HOLE.

REV. D	DRN BY KJB	CHK BY MCR	APP BY MCR	DATE 12/1/2021	DRN BY KJB	DATE: 12/1/2021
DESCRIPTION STANDARD DRAWINGS.					CHK BY MCR	DATE: 12/1/2021
ECN NO. N/A					APP BY MCR	DATE: 12/1/2021

PROPERTY AND CONFIDENTIAL NOTICE		TITLE <b>ATEVO BATTERY CHARGER OUTLINE: NEMA-1 STYLE-5054 ENCL 1Ø WITH COMMON OPTIONS 30-50A</b>
ANY REPRODUCTION, PARTIAL OR AS A WHOLE OF THIS DOCUMENT WITHOUT THE WRITTEN PERMISSION OF HINDLE POWER, INC IS STRICTLY PROHIBITED.		

<b>B</b>	SCALE	DWG No	REV	SHEET
	NTS	JE5251-22	D	1 OF 1

DUAL DIMENSIONS in [mm]

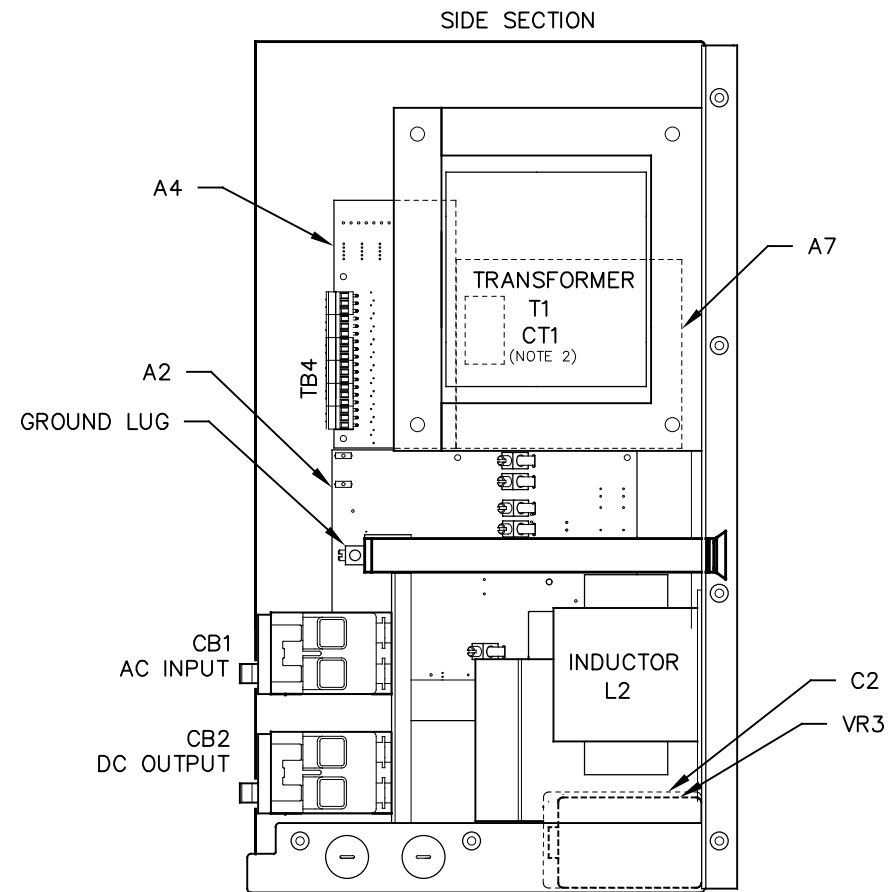
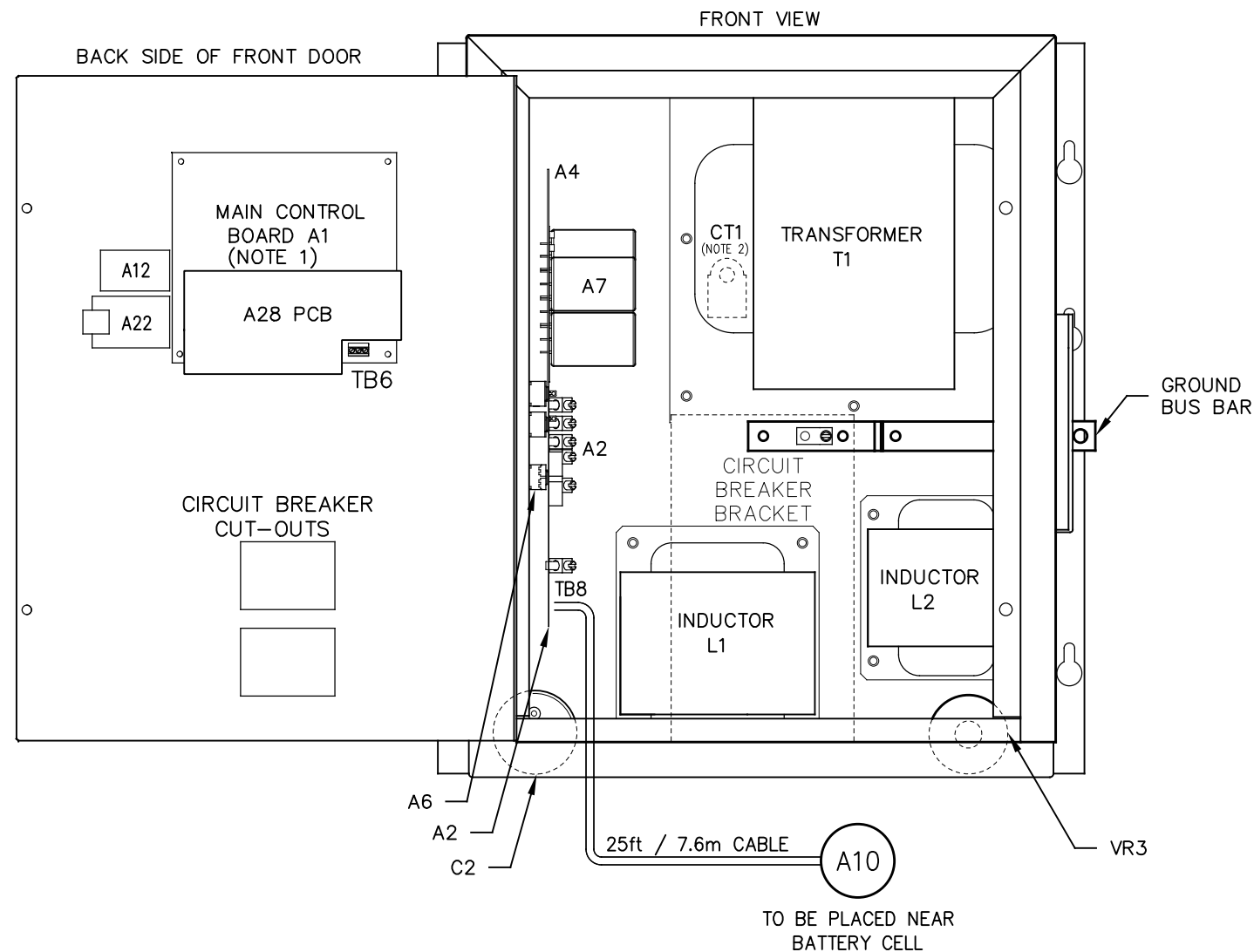

SYM	STANDARD COMPONENT DESCRIPTION
A1	MAIN CONTROL PC BOARD
A2	POWER BOARD
A6	RECTIFIER H/S ASSEMBLY
A7	FILTER BOARD (C1x/R9x)
A9	MOV BOARD
CB1	AC INPUT CIRCUIT BREAKER (Bx)
CB2	DC OUTPUT CIRCUIT BREAKER (Bx)
AUXCB2	DC CKT BKR (CB2) AUXILIARY CONTACTS
L1	MAIN INDUCTOR
L2	FILTER INDUCTOR
T1	POWER ISOLATION TRANSFORMER

SYM	FEATURED OPTION COMP DESCRIPTION
A4	AUXILIARY I/O BOARD
A10	TEMPERATURE COMPENSATION PROBE
A12	SERIAL COMMUNICATION ADAPTER
A22	ETHERNET COMM ADAPTER
AUXCB1	AC CKT BKR (CB1) AUXILIARY CONTACTS
C2	BATTERY ELIMINATOR FILTER CAP
TB4	AUX ALARM PCB (A4) TERM BLOCK
VR3	AC INPUT LIGHTNING ARRESTOR
A28	AC METER MODULE PC BOARD
CT1	CURRENT TRANSFORMER

NOTES:

- FOR DETAIL VIEWS OF ALL PC BOARDS (A1, A2, A4 etc.) SEE DRAWING JE5253-21.
- CURRENT TRANSFORMER AFFIXED TO LINE 1 BETWEEN AC INPUT BREAKER (CB1) AND POWER ISOLATION TRANSFORMER (T1). (SEE JA5124-21).

I/O TERMINAL	DESCRIPTION - TYPE	CONNECTION
CB2 (+/-)	POS/NEG DC OUTPUT TERMINALS - CKT BREAKER COMPRESSION LUG	#14-2/0 AWG
GND LUG	USER GROUND TERMINAL - CU-ALUMINUM COMPRESSION LUG	#14-6 AWG
CB1 (L1/L2)	AC INPUT TERMINALS - CKT BREAKER COMPRESSION LUG	#14-2/0 AWG
(A2) TB1	POS/NEG REMOTE SENSE TERMS (A2) - SOLDERLESS COMP SCREW	#22-14 AWG
(A2) TB8	TEMPCO PROBE (A10) TERM BLK - SOLDERLESS COMP SCREW	#22-14 AWG
(A4) TB4	AUX I/O RELAY CONTACTS (A4) - SOLDERLESS COMP SCREW	#22-14 AWG
(A1) TB6	SUMMARY ALARM TERMINAL BLOCK (A1) - SOLDERLESS COMP SCREW	#22-14 AWG
GND BUS	COPPER GROUND BUS - 0.375 in / 9.525 mm DIA HOLE	0.38in/9.7mm RING LUG

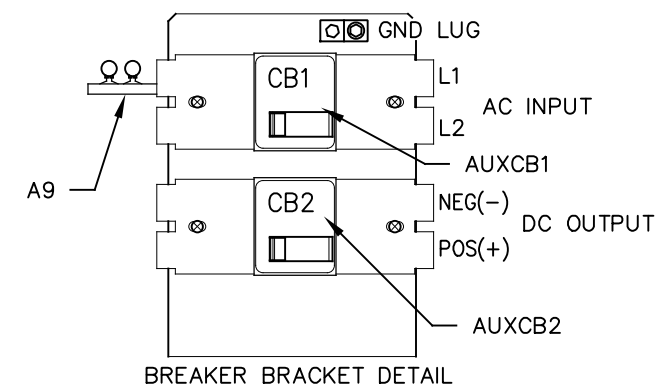

REV. DRN BY	CHK BY	APP BY	DATE	DRN BY	DATE:	TITLE <b>ATEVO BATTERY CHARGER INTERNAL COMPONENT LAYOUT: STYLE-5054 1Ø WITH COMMON OPTIONS 30-50A</b>	
D	KJB	MCR	MCR	12/1/2021	KJB		12/1/2021
DESCRIPTION STANDARD DRAWINGS.			CHK BY	DATE:	MCR		12/1/2021
ECN NO. N/A			APP BY	DATE:	MCR		12/1/2021
PROPERTY AND CONFIDENTIAL NOTICE ANY REPRODUCTION, PARTIAL OR AS A WHOLE OF THIS DOCUMENT WITHOUT THE WRITTEN PERMISSION OF HINDLE POWER, INC IS STRICTLY PROHIBITED.						TITLE	
						SCALE DWG No	
B NTS						JE5252-22	
REV D						SHEET 1 OF 1	

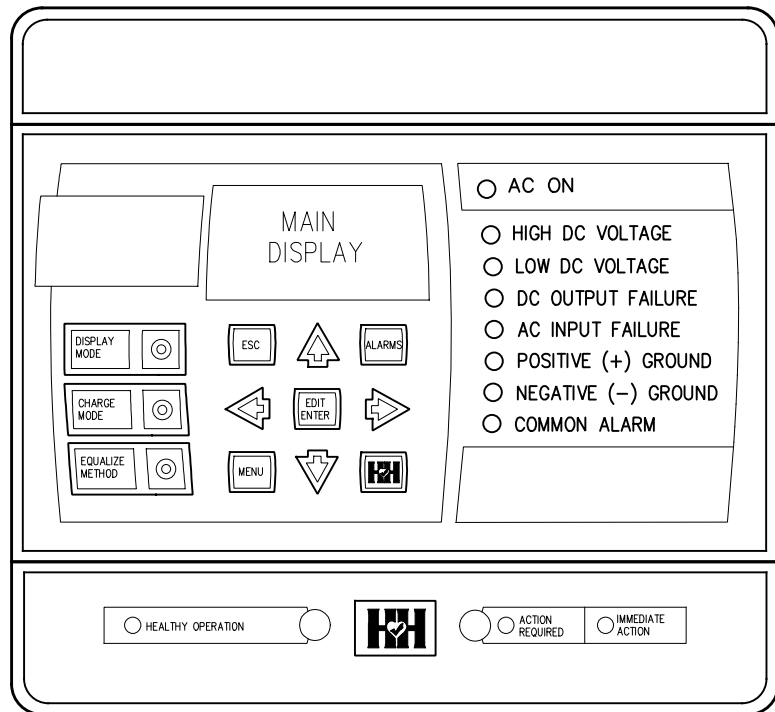

**CONTROL PANEL**  
(PART No. FK5047-00)

NOTE: ALL ALARM CONTACTS ARE ENERGIZED WHEN IN THE NON-ALARM STATE (FAIL SAFE). ALL ALARM CONTACTS WILL CHANGE STATE WHEN CHARGER IS POWERED DOWN. CONTACT RATING IS 0.5A @ 125VAC/VDC RESISTIVE.

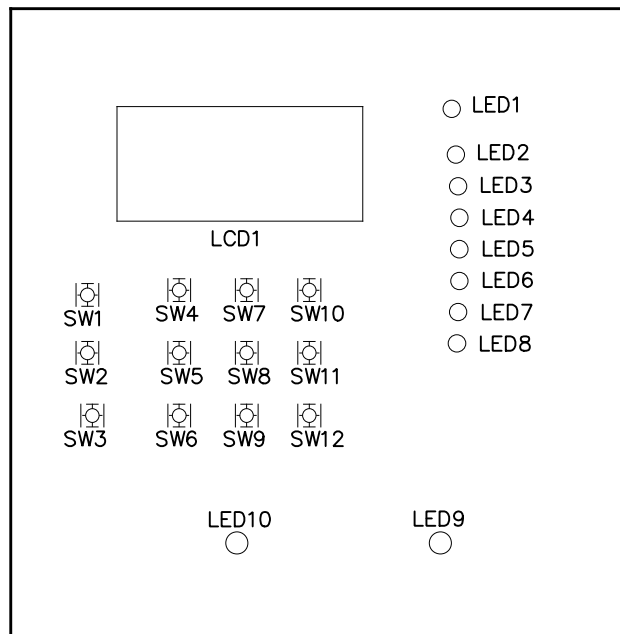

**MAIN CONTROL PC BOARD (A1)**  
FRONT VIEW – FACING CHARGER DOOR WHEN INSTALLED

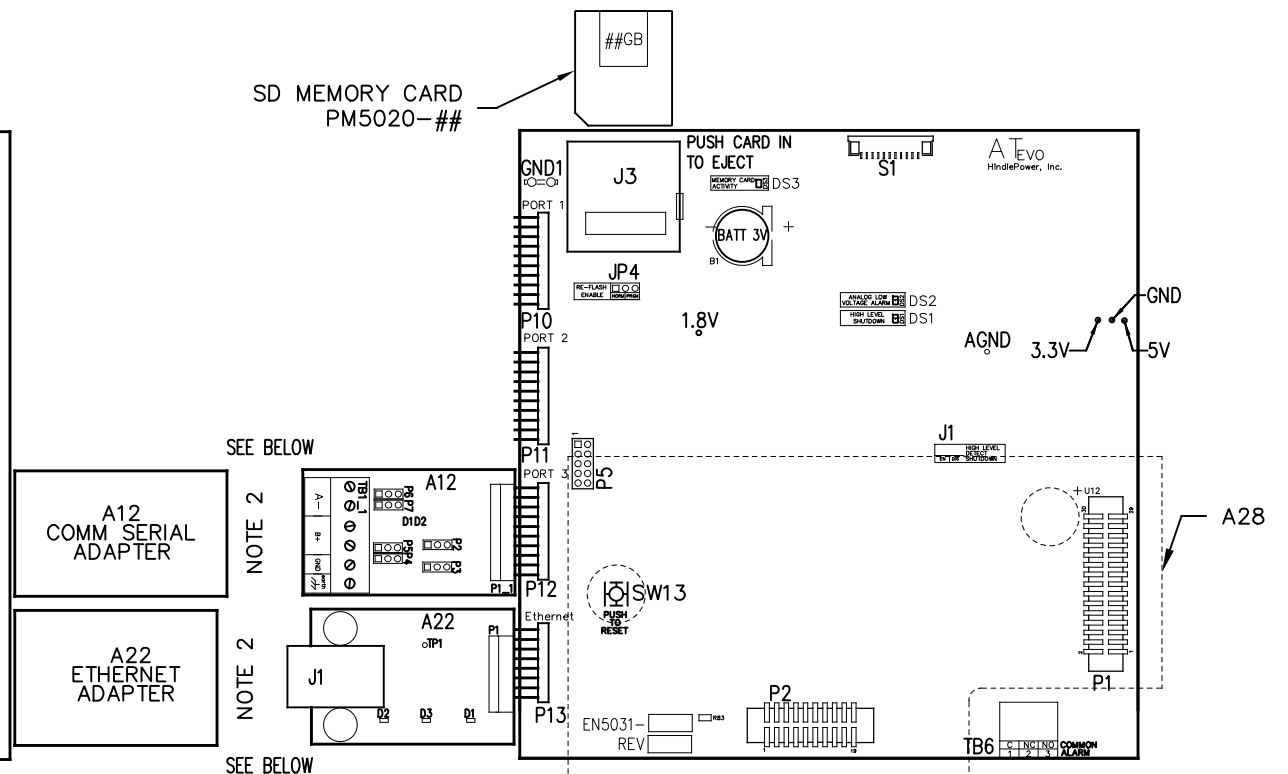

**MAIN CONTROL PC BOARD (A1)**  
BACK VIEW – FACING CHARGER COMPONENTS WHEN INSTALLED

2. SERIAL ADAPTER (A12) SUPPORTS MULTIPLE PROTOCOLS (DNP3 AND MODBUS) SIMULTANEOUSLY. SEE JA0102-54.

**SERIAL COMMUNICATION ADAPTER (A12)**

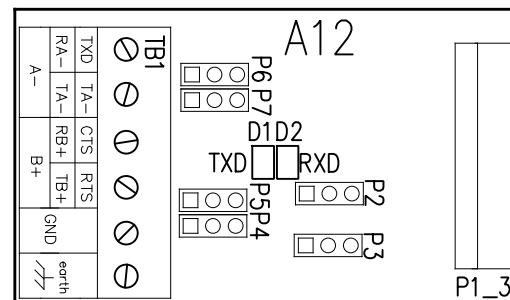

**CONNECTORS (A12):**  
P1 – MAIN CONTROL BOARD

**JUMPERS & CONFIGURATION SWITCHES (A12):**  
P2 – RECEIVER ENABLE CONTROL SELECTION  
P3 – MEDIA CONTROL SELECTION (RS-234 OR RS-485)  
P4 – RS-485 TERMINATION RESISTOR ENABLE (RECEIVE)  
P5 – RS-485 TERMINATION RESISTOR ENABLE (TRANSMIT)  
P6 – RS-485 INTERFACE 2 WIRE/4 WIRE SELECTION (A)  
P7 – RS-485 INTERFACE 2 WIRE/4 WIRE SELECTION (B)

**TERMINAL BLOCKS (A12):**  
TB1 – USER CONNECTIONS TO SERIAL INTERFACE

**INDICATOR LIGHTS (A12):**  
TXD (D1) – SERIAL DATA BEING SENT  
RXD (D2) – SERIAL DATA BEING RECEIVED

**ETHERNET ADAPTER (A22)**

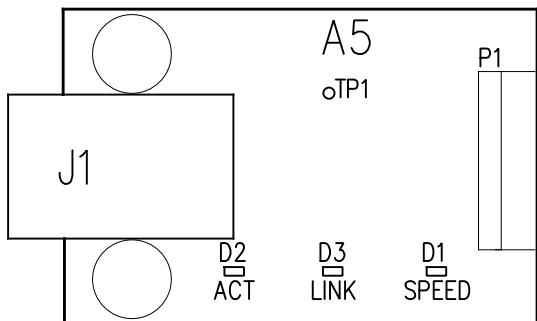

**CONNECTORS (A5):**  
P1 – MAIN CONTROL BOARD  
J1 – RJ-45 ETHERNET USER CONNECTION

**INDICATOR LIGHTS (A5 LEDs):**  
D1 – ORANGE – ETHERNET SPEED INDICATION 10/100 MBPS  
D2 – YELLOW – ETHERNET ACTIVITY (FLASHING)  
D3 – RED – ETHERNET LINK

**TEST POINTS (A5):**  
TP1 – CLOCK OUT

**AC METER MODULE PC BOARD (A28)**  
MOUNTED ON MAIN CONTROL PC BOARD

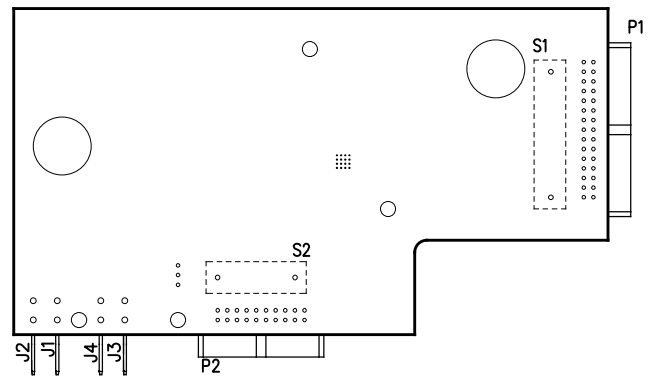

MAIN CONTROL PC BOARD (A1)			
<b>INDICATOR LIGHTS (LEDs):</b> LED1 – GREEN – AC ON LED2 – RED – HIGH DC VOLTAGE ALARM LED3 – RED – LOW DC VOLTAGE ALARM LED4 – RED – DC OUTPUT FAILURE ALARM LED5 – RED – AC INPUT FAILURE ALARM LED6 – RED – POSITIVE (+) GROUND ALARM LED7 – RED – NEGATIVE (-) GROUND ALARM LED8 – RED – COMMON ALARM LED9 – RED – ACTION REQUIRED ALARM LED10 – GREEN – HEALTHY OPERATION DS1 – RED – HIGH LEVEL SHUTDOWN (HLD) DS2 – RED – ANALOG LOW VOLTAGE ALARM (LLD) DS3 – RED – MEMORY CARD ACTIVITY	<b>JUMPERS:</b> J1 – ANALOG HIGH VOLTAGE SHUTDOWN JUMPER J3 – SD CARD PORT JP4 – RE-FLASH (FIELD PROGRAMMING) JUMPER <b>TERMINAL BLOCKS:</b> TB6 – COMMON ALARM RELAY CONTACTS <b>TEST POINTS:</b> 1.8V – 1.8 VOLTS 3.3V – 3.3 VOLTS 5V – 5.0 VOLTS GND – GROUND AGND – ANALOG GROUND SDA – MAIN BOARD 12C DATA SCL – MAIN BOARD 12C CLOCK	<b>SWITCHES:</b> S1 – DISPLAY BUTTON S2 – CHARGE MODE BUTTON S3 – EQUALIZE METHOD BUTTON S4 – ESCAPE (ESC) BUTTON S5 – LEFT ARROW BUTTON S6 – MENU BUTTON S7 – UP ARROW BUTTON S8 – EDIT / ENTER BUTTON S9 – DOWN ARROW BUTTON S10 – ALARM BUTTON S11 – RIGHT ARROW BUTTON S12 – HINDLE HEALTH (HHS) BUTTON SW13 – SYSTEM RESET BUTTON (BACK OF BOARD)	<b>CONNECTORS:</b> P1 – POWER BOARD RIBBON P2 – 3 PHASE RECTIFIER RIBBON P3 – USB EXPANSION PORT P4 – SPI & I2C EXPANSION PORT #1 P5 – SPI & I2C EXPANSION PORT #2 P6 – DISPLAY SPI PORT P7 – DISPLAY JTAG PORTS P10 – SERIAL INTERFACE PORT #1 P11 – SERIAL INTERFACE PORT #2 P12 – SERIAL INTERFACE PORT #3 P13 – ETHERNET INTERFACE PORT P17 – GENERAL EXPANSION PORT

I/O TERMINAL	DESCRIPTION – TYPE	CONNECTION
(A1) TB6	SUMMARY ALARM TERMINAL BLOCK (A1) – SOLDERLESS COMP SCREW	#22-14 AWG
(A12) TB1	RS-232 / RS-485 USER CONNECTIONS – SOLDERLESS COMP SCREW	#22-14 AWG
(A22) J1	SERIAL ETHERNET CONNECTION – RJ45 PLUG	CAT5

REV. DRN BY: D KJB	CHK BY: MCR	APP BY: MCR	DATE: 12/1/2021	DRN BY: KJB	DATE: 12/1/2021	<b>TITLE</b> <b>ATEVO BATTERY CHARGER</b> <b>CONTROL PANEL / PC BOARD DETAIL</b> <b>1Ø WITH COMMON OPTIONS 30-50A</b>
DESCRIPTION: STANDARD DRAWINGS.				CHK BY: MCR	DATE: 12/1/2021	
ECN NO. N/A				APP BY: MCR	DATE: 12/1/2021	
PROPERTY AND CONFIDENTIAL NOTICE ANY REPRODUCTION, PARTIAL OR AS A WHOLE OF THIS DOCUMENT WITHOUT THE WRITTEN PERMISSION OF HINDLE POWER, INC IS STRICTLY PROHIBITED.						<b>SCALE</b> B NTS
<b>DWG No</b> JE5253-22						<b>REV</b> D
<b>SHEET</b> 1 OF 2						

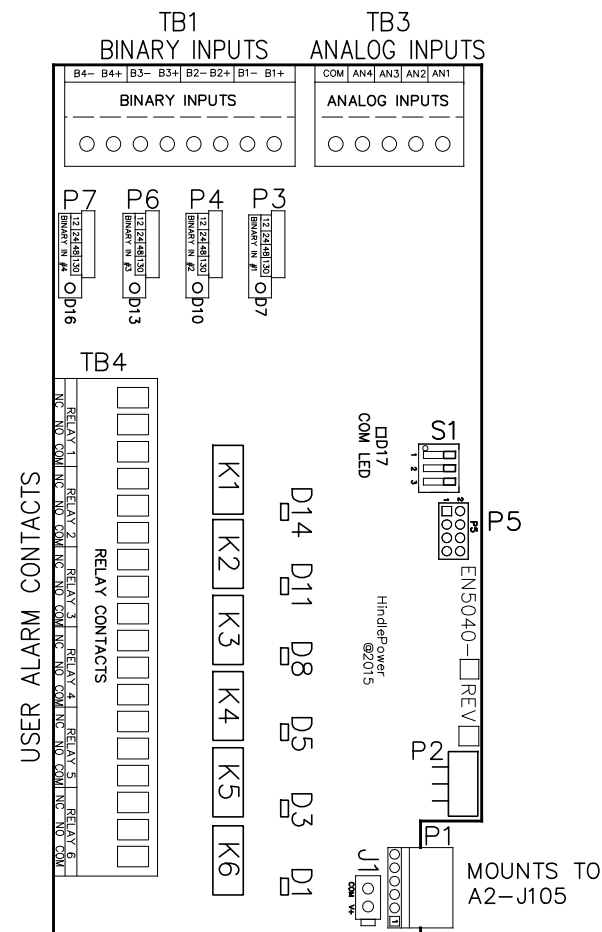

AUXILIARY I/O BOARD (A4)

JUMPERS & CONFIGURATION SWITCHES FOR AUX I/O BOARD (A4)  
 J1 - AUXILIARY POWER INPUT  
 P1 - POWER BOARD (PRIMARY POWER & COMM SOURCE)  
 P5 - PROGRAMMING HEADER

USER TERMINALS ON RELAY BOARD (A4):

- D1 - RED - RELAY #6 IN ALARM STATE
- D3 - RED - RELAY #5 IN ALARM STATE
- D5 - RED - RELAY #4 IN ALARM STATE
- D7 - YELLOW - BINARY INPUT #1 IS ABOVE THRESHOLD
- D8 - RED - RELAY #3 IN ALARM STATE
- D10 - YELLOW - BINARY INPUT #2 IS ABOVE THRESHOLD
- D11 - RED - RELAY #2 IN ALARM STATE
- D13 - YELLOW - BINARY INPUT #3 IS ABOVE THRESHOLD
- D14 - RED - RELAY #1 IN ALARM STATE
- D16 - YELLOW - BINARY INPUT #4 IS ABOVE THRESHOLD
- D17 - GREEN - COMMUNICATION TO MAIN BOARD (FLASHING)

USER TERMINALS ON RELAY BOARD (A4):

- TB1 - BINARY INPUTS
- TB2 - SERIAL INTERFACE
- TB3 - ANALOG INPUTS
- TB4 - AUXILIARY I/O RELAY CONTACTS

JUMPERS & CONFIGURATION SWITCHES

- P3, 4, 6, 7 - BINARY INPUT VOLTAGE CONFIGURATION JUMPERS
- S1 - BOARD ADDRESS DIPSWITCH

FILTER BOARD (A7)

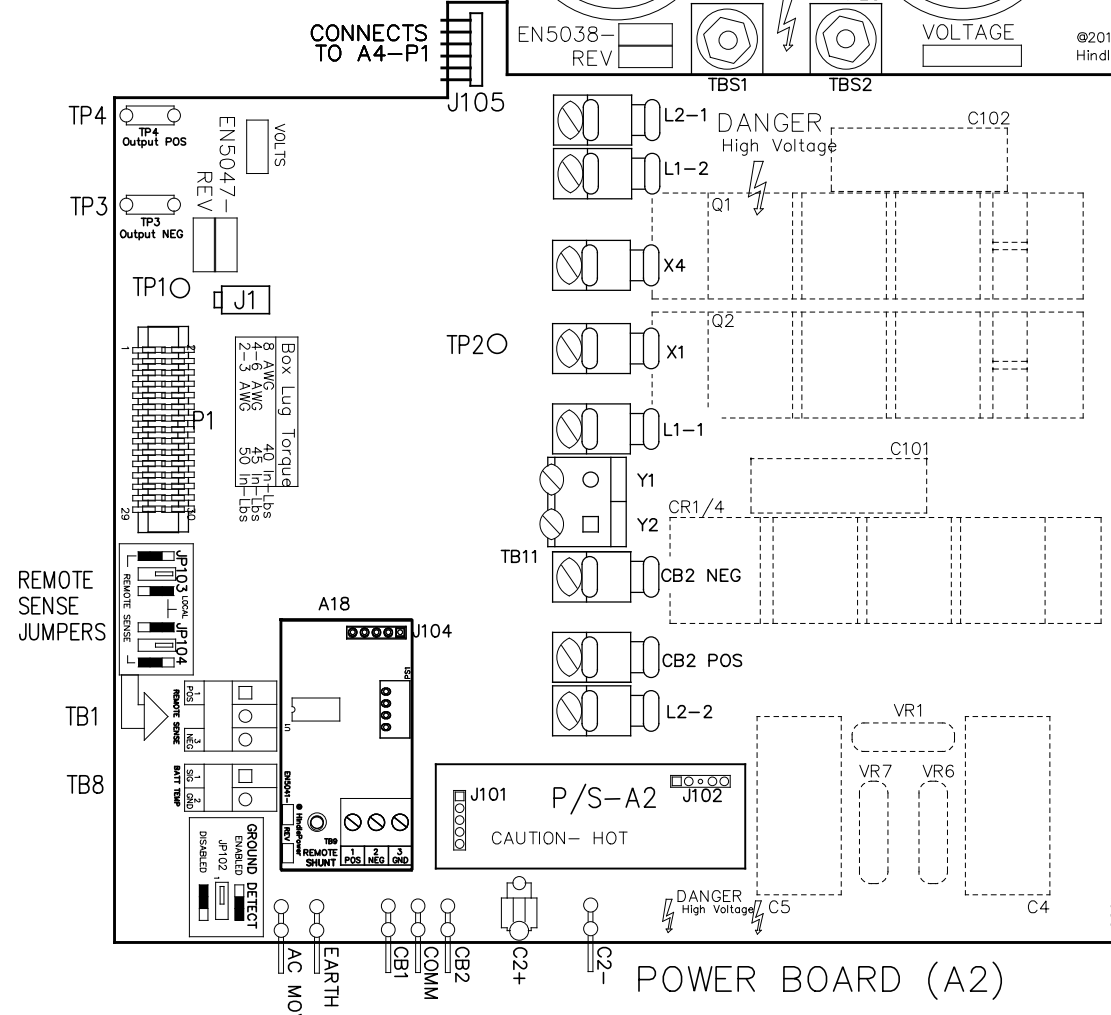
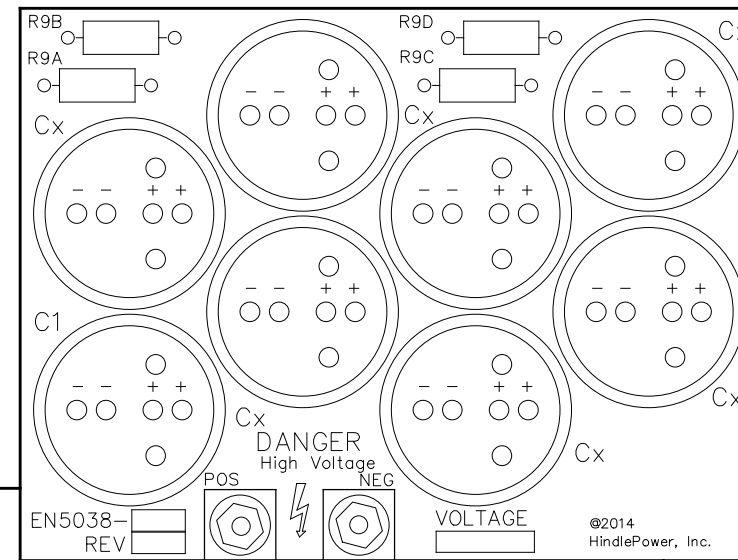

- USER TERMINALS ON POWER BOARD (A2):  
 TB1 - REMOTE VOLTAGE SENSE  
 TB8 - BATTERY TEMPERATURE COMPENSATION
- JUMPERS ON POWER BOARD (A2):  
 JP102 - GROUND DETECT CIRCUIT ENABLE / DISABLE  
 JP103 - REMOTE OR LOCAL SENSE SELECTOR (+)  
 JP104 - REMOTE OR LOCAL SENSE SELECTOR (-)
- CONNECTORS ON POWER BOARD (A2):  
 J1 - POWER OUT  
 J101 - DC POWER SUPPLY  
 J102 - DC POWER SUPPLY  
 J105 - AUXILIARY I/O BOARD  
 P1 - MAIN CONTROL BOARD RIBBON
- DISCRETE TERMINALS:  
 AC MOV - CHASSIS EARTH GROUND  
 EARTH - CHASSIS EARTH GROUND (DOOR)  
 CB1 - AC BREAKER AUX SWITCH CONTACT  
 CB2 - DC BREAKER AUX SWITCH CONTACT  
 COMM - BREAKER AUX SWITCH COMMON  
 C2+ - ELIMINATOR FILTER CAPACITOR (+)  
 C2 - ELIMINATOR FILTER CAPACITOR (-)  
 X1 - TRANSFORMER SECONDARY WINDING  
 X4 - TRANSFORMER SECONDARY WINDING  
 L1-1 - FILTER INDUCTOR #1 (TERMINAL #1)  
 L1-2 - FILTER INDUCTOR #1 (TERMINAL #2)  
 L2-1 - FILTER INDUCTOR #2 (TERMINAL #1)  
 L2-2 - FILTER INDUCTOR #2 (TERMINAL #2)  
 TB10 - CB2 DC BREAKER  
 TB11 - 'Y' CONTROL WINDINGS  
 TBS1 - FILTER CAPACITOR BOARD (+)  
 TBS2 - FILTER CAPACITOR BOARD (-)
- TEST POINTS ON POWER BOARD (A2):  
 TP1 - PRE-FILTERED DC BUS (-)  
 TP2 - PRE-FILTERED DC BUS (+)  
 TP3 - DC BUS (-)  
 TP4 - DC BUS (+)

I/O TERMINAL	DESCRIPTION - TYPE	CONNECTION
(A2) TB1	POS/NEG REMOTE SENSE TERMS (A2) - SOLDERLESS COMP SCREW	#22-14 AWG
(A2) TB8	TEMPCO PROBE (A10) TERM BLK - SOLDERLESS COMP SCREW	#22-14 AWG
(A4) TB1	AUX I/O BINARY INPUTS (A4) - SOLDERLESS COMP SCREW	#22-14 AWG
(A4) TB2	AUX I/O RELAY CONTACTS (A4) - SOLDERLESS COMP SCREW	#22-14 AWG
(A4) TB3	AUX I/O ANALOG INPUTS (A4) - SOLDERLESS COMP SCREW	#22-14 AWG
(A4) TB4	AUX I/O RELAY CONTACTS (A4) - SOLDERLESS COMP SCREW	#22-14 AWG

TITLE				
ATEVO BATTERY CHARGER CONTROL PANEL / PC BOARD DETAIL 1Ø WITH COMMON OPTIONS 30-50A				
B	SCALE	DWG No	REV	SHEET
	NTS	JE5253-22	E	2 OF 2

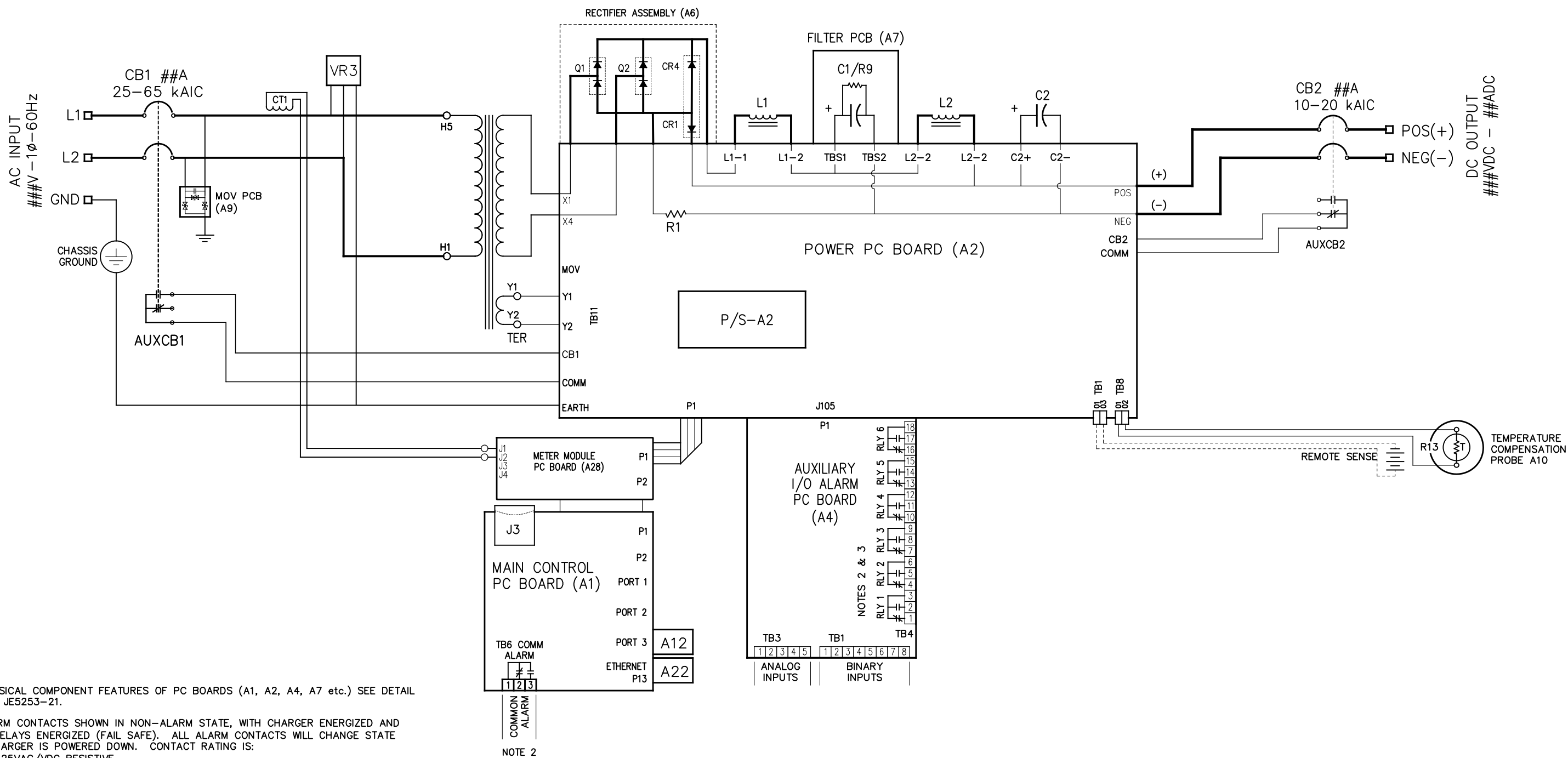

- NOTES:
- FOR PHYSICAL COMPONENT FEATURES OF PC BOARDS (A1, A2, A4, A7 etc.) SEE DETAIL DRAWING JE5253-21.
  - ALL ALARM CONTACTS SHOWN IN NON-ALARM STATE, WITH CHARGER ENERGIZED AND ALARM RELAYS ENERGIZED (FAIL SAFE). ALL ALARM CONTACTS WILL CHANGE STATE WHEN CHARGER IS POWERED DOWN. CONTACT RATING IS: 0.5A @ 125VAC/VDC RESISTIVE.
  - DEFAULT RELAY ALARM CONFIGURATION SHOWN BELOW. CAN BE CHANGED TO DESIRED CONFIGURATION BY USER.

A4	DESCRIPTION	LATCHING	DELAY
RELAY #1	HIGH VOLTAGE DC	DISABLED	30 SECONDS
RELAY #2	LOW VOLTAGE DC	DISABLED	30 SECONDS
RELAY #3	DC OUTPUT FAILURE	DISABLED	30 SECONDS
RELAY #4	LOW AC SUPPLY	DISABLED	30 SECONDS
RELAY #5	POSITIVE GROUND FAULT	DISABLED	30 SECONDS
RELAY #6	NEGATIVE GROUND FAULT	DISABLED	30 SECONDS

REV. DRN BY	CHK BY	APP BY	DATE	DRN BY	DATE:	
D	KJB	MCR	MCR	12/1/2021	KJB	12/1/2021
DESCRIPTION				CHK BY	DATE:	
STANDARD DRAWINGS.				MCR	12/1/2021	
ECN NO. N/A				APP BY	DATE:	
				MCR	12/1/2021	
PROPERTY AND CONFIDENTIAL NOTICE						
ANY REPRODUCTION, PARTIAL OR AS A WHOLE OF THIS DOCUMENT WITHOUT THE WRITTEN PERMISSION OF HINDLE POWER, INC IS STRICTLY PROHIBITED.						

TITLE				ATEVO BATTERY CHARGER SCHEMATIC: STYLE 5054 1φ WITH COMMON OPTIONS 30-50A	
SCALE	DWG No	REV	SHEET		
B	NTS	JE5254-22	D	1	1

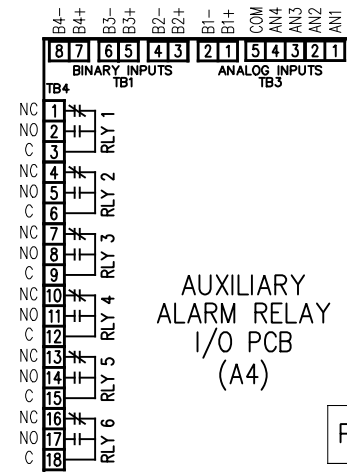

AUXILIARY ALARM RELAY I/O PCB (A4)

P1 CONNECTS TO A2-J105

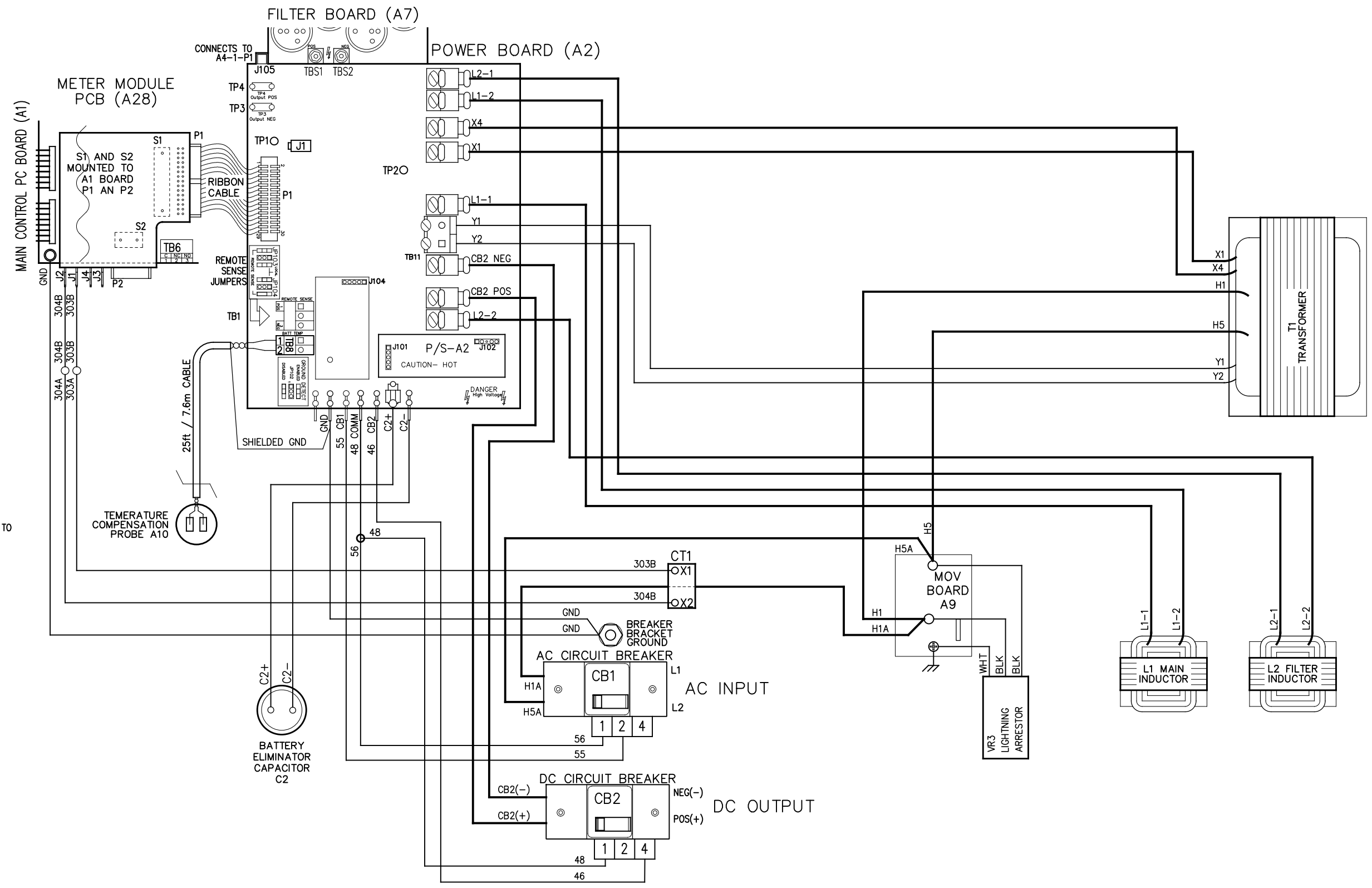

NOTES:  
 1. WHEN NATURAL LEADS OF MAGNETICS ARE NOT USED, CHARGER COMPONENTS ARE CONNECTED WITH BLACK FLAME-RETARDANT SWITCHBOARD INSULATION SYSTEM (SIS) TYPE WIRING, IDENTIFIED ON EACH END WITH NUMBER-CODED MARKERS. GROUND WIRES ARE GREEN WITH YELLOW STRIPE.

REV. DRN BY D KJB	CHK BY MCR	APP BY MCR	DATE 12/1/2021	DRN BY KJB	DATE 12/1/2021
DESCRIPTION STANDARD DRAWINGS.			CHK BY MCR	DATE 12/1/2021	
ECN NO. N/A			APP BY MCR	DATE 12/1/2021	TITLE
PROPERTY AND CONFIDENTIAL NOTICE ANY REPRODUCTION, PARTIAL OR AS A WHOLE OF THIS DOCUMENT WITHOUT THE WRITTEN PERMISSION OF HINDLE POWER, INC IS STRICTLY PROHIBITED.					
				<b>B</b> SCALE DWG No NTS JE5255-22	
				REV D	SHEET 1 OF 1

ATEVO BATTERY CHARGER  
 CONN DIAGRAM: STYLE 5054  
 1Ø WITH COMMON OPTIONS 30-50A